



P360

Propeller nozzle

07.2500



Operating Manual
English
November 25 | Version 2.2



Table of Contents

Table of Contents	1
Preface	3
Purpose of the document	3
1 Safety.....	4
1.1 Noncompliance with the safety information and its consequences	4
1.2 Target group	4
1.3 User requirements.....	4
1.4 Explanation of general safety instructions	5
1.5 Information provided in these operating instructions	5
1.6 Intended use.....	5
1.7 Safety warnings for modifications.....	6
1.8 Protective equipment for working in manholes, excavations, and sewer lines	6
1.9 General safety instructions.....	8
2 Legal	10
2.1 Copyright	10
2.2 Exclusion of liability	10
2.3 Warranty conditions.....	10
3 P360 propeller nozzle.....	11
3.1 Introduction.....	11
3.2 Application range	12
3.3 Operating principle.....	12
4 Installation.....	13
4.1 Installing the tools	13
4.2 Preparation.....	13
4.3 Setting up the work area	13
4.4 Setting up the P360 in the sewer	14
5 Operation.....	16
5.1 Operating the tool	16
5.2 Cleaning pipes with minor damage	17
5.3 After use	17
6 Maintenance.....	19
6.1 Maintenance after each use	19
6.2 Nozzle inserts	19
6.3 Drive modes.....	22
6.4 Lubricating the spindle	23
6.5 Replacing the connecting hose.....	23
6.6 Other maintenance	23
6.7 Troubleshooting	24

7 Technical specifications..... 26

7.1 Drawings.....27

7.2 Setup methods29

7.3 Adjusting the skids.....30

7.4 Adjusting the propeller for the pipe diameter31

7.5 Working underwater31

7.6 Securing the hose34

7.7 Installing the supplied pulling eye34

8 Accessories 35

9 Notes 37

10 Index..... 38

10.2 Drawings.....38

Version	Revision	Date	Initials
2.0	Created	November 24	bbi
2.1	Article numbers corrected	December 24	bbi
2.2	Article numbers corrected	November 24	bbi

Preface

Dear valued customer,

Thank you for the confidence and trust you've placed in us by purchasing one of our products.

We always appreciate suggestions and new design ideas. Your feedback will help us improve the design of our product and the associated documentation.

If you have any questions or suggestions, please contact our Customer Service Department.

enz® technik ag

Tel. +41 41 676 77 66

info@enz.com



Feedback form

www.enz.com/en/header/feedback

Person responsible for the documentation:

Bryan Bieri (Tech. Support / QM Manager)

We reserve the right to modify and further enhance our products without prior notice as a result of technological advances. Misprints reserved.

Purpose of the document

The purpose of this manual is to instruct you on how to use our product correctly, effectively, safely, and for its intended purpose. The user will be informed about risks, reasonably foreseeable misuse, and residual risks.



Important!

Read carefully before use.

Keep for later reference.

Please read this operating manual thoroughly before using the cleaning tool. Make sure that all employees who work with the product know how to use it correctly.

The operating manual must be available to all operating personnel at all times. It must be kept in an easily accessible place.

If the manual is misplaced or destroyed, a new copy can be requested from your nearest dealer or from the manufacturer directly.

1 Safety

1.1 Noncompliance with the safety information and its consequences

Disregarding these safety instructions may lead to accidents and severe personal injuries, material damage, and damage to the environment.

The manufacturer cannot be held responsible for any damages resulting from non-compliance with these instructions.

1.2 Target group

This manual is intended for all persons who will be involved in the assembly, start-up, and operation of the pipe cleaning tool.

1.3 User requirements

Personnel intending to assemble, start up and operate the tool must...

- Be familiar with the field of sewer maintenance work and possess the appropriate technical knowledge.
- Be trained and instructed appropriately in the use of the product.
Have read and understood the operating manual, in particular the section on "**Safety**"

If your personnel do not possess the necessary knowledge, they must be trained and instructed on it. If necessary, the pipe cleaning tool manufacturer can provide this instruction and training.

Only the maintenance and service activities described in this manual may be performed by users who have met the above-listed requirements. Any additional maintenance and service work may be performed only by qualified specialist personnel from the manufacturer.



Please refer to the section on "**Maintenance**".

1.4 Explanation of general safety instructions

The general safety instructions in this section provide information about potential residual risks, which are inherent to the product and may occur unexpectedly, despite the proper usage of the product.

In order to prevent personal injuries, material damage, and damage to the environment, all personnel working with this product must comply with these safety instructions. It is mandatory for said personnel to read and to understand the information provided in this section.

1.5 Information provided in these operating instructions



DANGER!

Noncompliance may lead to serious injury or **loss of life**.



WARNING!

Noncompliance may lead to serious injury and / or cause a long-term disability.



CAUTION!

Noncompliance may lead to injury and considerable material damage, financial loss or damage to the environment.



Information on the technically correct and efficient use of the product.

1.6 Intended use

The product is designed to clean the insides of pipes (sewer pipes). The following points must be followed to ensure proper use of the product:

- ⚠ The cleaning tool may be used only in pipes or pipe-like sewers. The profile to be cleaned must be free of leaks and surrounded by material.
- ⚠ The tool may be used on the following types of pipes:
 - PE pipes
 - Steel pipes
 - Concrete pipes
 - Stoneware
 - Ceramic
 - Clay
 - PVC
 - Fiber cemen

- ⚠ For use in pipes made of other material, please consult the manufacturer.
- ⚠ The product may be operated only in pipes with correctly installed and defect-free connections.
- ⚠ Cleaning areas (manholes, pipe branches etc.) need to be sufficiently secured during the operation, including during construction and cleaning work.
- ⚠ During the cleaning operation, **no** personnel are allowed inside the pipes or at either end of the pipes.
- ⚠ The maximum pressure indicated on the nozzle may **not** be exceeded.
- ⚠ Wastewater may **not** be drained into watercourses (creeks, rivers etc.).
- ⚠ The product must be inspected to ensure it is in proper working order before every start-up.
- ⚠ Defects must be rectified before start-up.
- ⚠ Use the tool only as intended. (Use only the correct wrench for nuts).
- ⚠ Secure the hose lines in such a way that they cannot become damaged during operation.
- ⚠ Only the accessories provided and approved by **enz® technik ag** may be used.

1.7 Safety warnings for modifications

No other changes or modifications to the pipe cleaning tool may be performed. Only parts authorized by the manufacturer may be used. The manufacturer is not liable for damage resulting from unauthorized changes to the product.

1.8 Protective equipment for working in manholes, excavations, and sewer lines

The employer must provide suitable personal protective equipment and ensure that it is worn by the employees during work.

In the following section, the protective equipment prescribed by Schweizerische Unfallversicherung SUVA (the Swiss Accident Insurance Organization) will be described.

For more information on this, refer to the brochure:

**Safe entry and working in manholes, excavations, and sewer lines
(in German, French & Italian)**

Order number: 44062.d

Suva
Schweizerische Unfallversicherungsanstalt
Arbeitsicherheit
Postfach, 6002 Lucerne, Switzerland
For information:
Phone +41 41 419 51 11
For orders:
www.suva.ch/waswo
Phone +41 41 419 58 51



Respirators

Self-contained respiratory equipment for spending time in dangerous atmospheres and for use during rescue operations.



Respirators

Self-rescue respiratory equipment (devices with compressed air tanks or regeneration devices) for working in sewers and for first aid for injured persons.



Rescue harness

Rescue harness or protective clothing with a loop sewn into the neck. During rescue, the rescue rope will be attached to the neck loop. Injured persons will be lifted out using a rescue lifting device with a self-actuating load brake.



Suitable working clothing

Leak-proof clothing protects the skin from becoming soiled and from possible infections. Visually conspicuous work clothing makes the employee more visible to traffic.



Appropriate footwear

Safety footwear should, in particular, have good grip and be slip-resistant and leak-proof (e.g. rubber boots).



Gloves

Appropriate gloves will protect you from hand injuries and contact with materials that could impair your health and from untreated water.



Hardhat

The hardhat will protect your head from falling objects and from bumping into fixed components and objects.



Hearing protection

If there is noise that could damage your hearing, you must wear, e.g. earmuffs with built-in headphones and microphone.



Eye protection

Your eyes should be protected against grit, sprayed dangerous substances, etc.



Lighting independent of the power grid

For example, you should carry a waterproof flashlight or wear a flashlight attached to your hardhat.

1.9 General safety instructions



Danger! | High-pressure water jets

Defects in or unintended use of the product could cause hazards due to pressurized water spray. Never remain in the channel during operation. Ensure that the product is in perfect condition before operation. Highly concentrated water jets can cause serious injury and could even sever limbs.



Danger! | Toxic vapors

There can be toxic vapours in sewer lines. Wear the prescribed protective equipment such as gas masks, gas warning devices and rescue harnesses. Inhaling toxic vapours or air that is contaminated with particles could be **fatal** or lead to serious injuries if the particles enter the lungs.



Warning! | Falling objects

Around open manholes, objects can fall down into the manhole and onto the people below. Never remain directly beneath the manhole opening when guiding the products in. Secure the manhole entrance against parts that could fall. Do not throw any tools or objects down into the manhole. Do not enter any manhole where there is a danger of falling. Personnel could become trapped.



Warning! | Chemical burns

There may be unidentified, corrosive, or otherwise harmful substances in the sewer line. Put on appropriate protective clothing. Use the protective equipment prescribed. Otherwise, you could suffer from chemical burns to your skin and eyes or become infected with pathogens.

**Warning! | Falls from height**

Open manholes are to be expected in the area where you will be working with the product. You must warn people about open manholes. Pay attention to where you are walking.

**Warning! | Hand injuries**

In case of tampering with the product, there is a risk of hand injury due to getting caught or abrasion. Wear gloves during work. Pay attention to where you grip the product. Always have sufficient people carry heavy, or over-sized, equipment. Consequences can include crushing injuries, abrasions or even the loss of a limb.

**Caution! | Sharp objects**

If the product is tampered with, there is a risk of hand injuries due to sharp edges. Wear gloves during work. Pay attention to where you grip the product. Consequences can include cutting injuries to your hands or other parts of your body.

**Caution! | Trip hazards**

Lines and other objects are to be expected on the ground in the area around where the product is being used. Pay attention to where you are walking. Keep the area of use tidy. Tripping and falling could cause serious injuries.

2 Legal

2.1 Copyright

Without enz® technik ag's prior written consent, this manual may not be reproduced, photocopied, translated, or altered in whole or in part.

©2025 enz® technik ag, 6074 Giswil, Switzerland.
All rights reserved.

2.2 Exclusion of liability

The manufacturer is not liable for damage that:

- Is caused as a result of unauthorized changes to the product.
- Is caused by not following the safety instructions.

2.3 Warranty conditions

In accordance with our sales and delivery conditions, we offer a warranty. However, the warranty is voided if:

- The product is used under conditions that are not permitted by us.
- Replacement and accessory parts that are not original replacement and accessory parts from **enz® technik ag** are used.
- If there is damage due to:
 - Improper use
 - Not following the operating manual
 - Unsuitable operating equipment
 - Incorrect or improper routing of the hose or pipelines
 - Unauthorized changes or modifications to or conversions of the product.

3 P360 propeller nozzle

3.1 Introduction

The P360 propeller nozzle enables thorough all-around cleaning of large sewers with a diameter of 600 mm – 3000 mm. It's easy to change the application diameter. This nozzle is suitable for use in round, flat, or egg-shaped profiles. Although the P360 was designed for operation with recycled water, it can also be operated with fresh water.

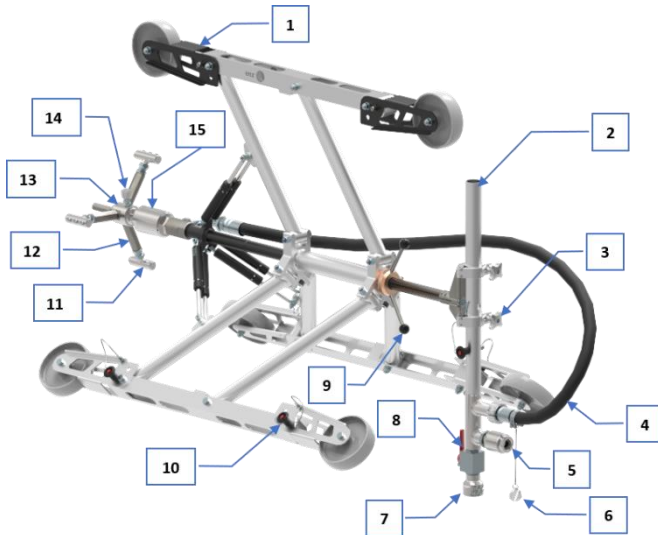

Figure 1 Parts overview for P360

Key:

- | | |
|---|-------------------------------------|
| 1. Wheel carrier | 9. Rotary lever |
| 2. Thrust part – includes 4, 5, 6, 7, 8 | 10. Locking pin |
| 3. Star grip | 11. Cleaning nozzle |
| 4. Connecting hose | 12. Propeller arm |
| 5. Swivel joint | 13. Propeller – includes 11, 12, 14 |
| 6. Hose cap | 14. Rotational drive |
| 7. Thrust part | 15. Rotating joint |
| 8. Thrust valve | |
| 16. | |

3.2 Application range

The P360 propeller nozzle is specially designed to remove grease and stubborn deposits on pipe walls. It's perfect for comprehensive cleaning before inspection with a camera. The Underwater Kit makes it possible to use the P360 underwater.

3.3 Operating principle

The design of the P360 is based on the Bulldog® rotating nozzle, so it can be operated with recycled water. Water flows to the propeller arms via the rotating joint and is directed at the pipe wall via the nozzle inserts. There is a drive jet that powers the propeller.

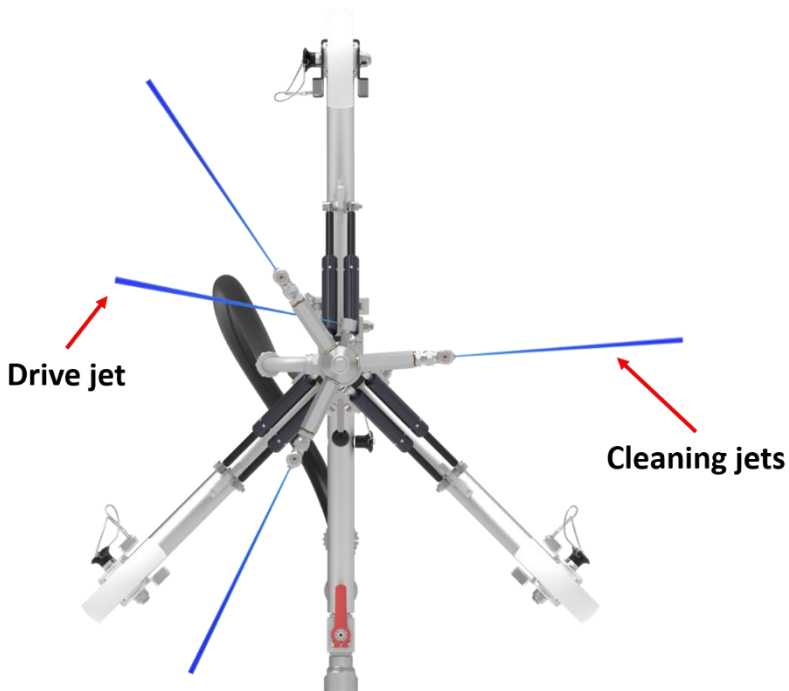

Figure 2 Operating principle of P360

4 Installation

4.1 Installing the tools

The tools are supplied ready for use. After unpacking, check the delivery for completeness.







4.2 Preparation

It is a good idea to clarify some points before use. Knowledge of the following points is helpful during preparation and when adjusting the propeller nozzle:

- Routing of lines.
- Inside diameter of the sewer where work will be performed.
- Material of the sewer where work will be performed.
- Type of foreign material in the pipe.
- Recommended flushing direction. → We recommend working against the direction of flow.
- Slopes in the sewer where work will be performed.
- Sewer access points.

4.3 Setting up the work area

Perform the following before working with a propeller nozzle:

-  Set up barriers and safety equipment (warning signs, safety barriers, etc.).
-  Block off and secure the work area such that there is no risk of falling or of danger from traffic.
-  Obtain information regarding the wastewater entering the manhole (chemicals, gas, vapors, etc.).
-  Measuring instruments such as explosive gas meters, oxygen meters, and gas detectors must be readily available.
-  Ensure that the appropriate nozzle sizes for cleaning the pipes are available. See “Technical specifications” in **Section 7** on **page 26** for the application range of the nozzle.
-  The layout of the lines (sewer maps) must be known before starting work to prevent the nozzle from emerging at a pipe end. Support personnel must monitor possible emerging points.

-  Have the customer sign the liability waiver to protect against claims for damages.



Figure 3 Cordoned-off & identified work area

4.4 Setting up the P360 in the sewer

Rinse the sewer with a standard nozzle before inserting the P360 propeller nozzle into the sewer. This prevents loose material from blocking the nozzle.



CAUTION

Ensure that the sewer has no obstacles or deposits. In particular, check pipe inlets, headers, lines, etc. The nozzle must be able to move freely in the sewer. Considerable damage could result if the nozzle remains in one place.

4.4.1 Guiding the propeller nozzle into the sewer

The P360 is designed so it can be lowered into the sewer system via a 600 mm manhole without tools. Prepare the propeller nozzle as follows:

1. Remove the connecting hose. Disconnect it from the thrust part. Connect the hose cap. This prevents foreign materials from entering the hose.
2. Remove the thrust part from the rest of the nozzle. To do so, loosen the star grip for the thrust fastener.



Do not unscrew the star grips too much – you could lose them.

3. Adjust the skids for the smallest possible diameter. See **Section 7.3** on **page 30**.
4. Attach the end of the nozzle to a cable winch. Slowly lower the P360 into the manhole. Do not allow the head of the nozzle to hit the sewer floor.

**CAUTION**

The use of a cable winch to lower the propeller nozzle into the manhole is mandatory. Failure to comply presents an increased risk of back injury.



Figure 4 P360 being lowered into manhole

4.4.2 Setup in the sewer

This section describes how to set the nozzle up in the sewer. The process depends on the space available in the sewer. If possible, work against the direction of flow (from bottom to top).

1. Set the P360 up based on the sewer shape. See **Section 7.2** on **page 29**.
2. Adjust the skids to match the pipe diameter. Turn the rotary lever clockwise to do so. Fold the wheel carriers out if needed. See **Section 7.3** on **page 30**.
3. Install the propeller extensions if needed. See **Section 7.4** on **page 31**.
4. Install the thrust part and connecting hose. See **Sections 7.5.3** and **7.6** on **page 34**.
5. Attach the rinsing hose. Ensure no foreign materials enter the hose.

5 Operation

5.1 Operating the tool

1. Use a sewer pipe video camera to check whether the pipe is suitable for cleaning with a propeller nozzle (pipe layout, condition, fragility, etc.).
2. Increase the water pressure on the P360 to a maximum of 100 bar (1450 psi) (consider the pressure loss in the hose). We recommend a maximum of 80 bar (1160 psi) at the nozzle for sensitive and fragile pipes.
3. Pay attention to the speed of the propeller – it should be easy to hear the propeller. See **Section 6.2, page 19** regarding the configuration of the drive jet.
4. Clean the first 2 meters (6 feet) of the sewer. Check the cleaning performance.
5. Pay attention to the sound of operation and the forward motion of the nozzle while unrolling the hose. If there are irregularities, see “Troubleshooting,” **Section 6.7 on page 24**.
6. Keep the water running while retracting the propeller nozzle. This prevents wastewater from entering the nozzles.
7. Close all manhole covers after work.



WARNING

Do not exceed the maximum working pressure stated in **Section 7 on page 26**. Failure to comply could cause the nozzle to explode.



CAUTION

Never let the tool skip, such as by pulling the hose back and releasing it suddenly. Damage could result.



Continue to run the water at low pressure when retracting the tool. This prevents wastewater from entering the tool via the nozzle inserts, which could lead to failure of the propeller nozzle.

5.2 Cleaning pipes with minor damage

Minor damage is usually considered to be cracks in the pipe wall. Inform the customer or the appropriate authorities if you notice these issues.

Use extreme caution when working in pipes with minor damage. Use the tool at your own risk. **enz® technik ag** waives all liability.



DANGER

When cracks are washed out, pipe fragments can break off, and the material surrounding the pipe may be washed out. The sewer could collapse. Do not use the equipment if this could occur.



If you must clean fragile pipes, replace the nozzle inserts with fan jet nozzles for less aggressive water jets.

5.3 After use

5.3.1 Removing the nozzle from the sewer

Bring the P360 up to the surface after use via the manhole. Perform the following:

1. Ensure that the P360 is not under pressure.
2. Remove the rinsing hose.
3. Rinse soiling on the P360 with fresh water.
4. Remove the connecting hose from the thrust part. Remove the thrust part. Ensure no wastewater enters the openings by attaching the hose cap to the connecting hose.
5. Remove the propeller extensions if necessary.
6. Fold in the wheel carriers. Turn the rotary lever until the skids are fully retracted. See **Section 7.3** on **page 30**.
7. Pull the nozzle out of the manhole using a cable winch.



Cleaning the P360 first makes it easier to collapse the equipment down.

5.3.2 Completing work

If possible, use a sewer pipe video camera to inspect the cleaned pipes. Check for damage and the leakage of fluids into the environment.

Close manholes after cleaning the sewer.

5.3.3 Transport

Secure everything on the P360 for transport. The connecting hose can be secured to the P360 with the hose belts. The thrust part is usually transported separately.

6 Maintenance

The maintenance and service activities described in this manual may only be performed by users who have the required knowledge.

6.1 Maintenance after each use

1. Check whether the nozzle inserts are clogged.
2. Check the tool for wear. Replace defective parts.
3. Clean the skid adjustment spindle. Apply high-performance grease (Art. No. 14.99008) to the spindle. See **Section 6.4** on **page 23**.
4. For corrosion protection and care, treat the tool with OIL SPRAY BIO (Art No. C191).



Figure 5 OIL SPRAY BIO, 500 mL

Spray the nozzle holes and the connecting threads with OIL SPRAY BIO (Art No. C191) in preparation for extended storage.

6.2 Nozzle inserts

Regularly inspect the nozzle inserts. Wear depends on the degree of contamination of the water used. If recycled water is used, inspect the nozzle inserts **daily** and clean them if necessary.



CAUTION

Worn nozzle inserts limit cleaning performance and increase risk when working with high pressure. Inspect the nozzle inserts daily if recycled water is used.

Use JetCalc to determine the diameter of the nozzle inserts if you do not know it.

6.2.1 Replacing the nozzle inserts

1. Remove the defective nozzle inserts.
2. Clean the threaded holes as well as the threads on the new nozzle inserts. All threads must be free of lubricant.
3. Coat the threads of the nozzle inserts with Loctite 243 (Art. No. C192).
4. Immediately screw the nozzle inserts into the tool body as far as they will go. Hand-tighten the inserts.
5. The compound must cure for at least 24 hours.

**CAUTION**

Only replace damaged nozzle inserts with identical nozzle inserts of the same diameter. If the tool is not correctly outfitted, the tool or the pipe may be damaged.

6.2.2 Fitting per enz® JetCalc

There are several fitting options for the P360. The rotational drive and the three propeller arms with three nozzle inserts each must be optimized for the thrust. Use the JetCalc nozzle calculation program at <https://my.enz.com> to calculate the parameters of the nozzle inserts for the propeller nozzle.

JetCalc calculates three fitting options for achieving the desired flow rate:

- Fitting B1 → 1 nozzle insert per nozzle head
- Fitting B2 → 2 nozzle inserts per nozzle head
- Fitting B3 → 3 nozzle inserts per nozzle head

Use fitting option B3 for the best cleaning result if the flow rate is sufficient. Do not use nozzle inserts smaller than $\varnothing 1.5$ mm, which reduces the nozzle's capacity for use with recycling water.

Using a smaller or larger insert on the rotational drive changes the rotational speed.

**CAUTION**

Never change the direction of rotation of the propeller. Parts of the P360 could come off during use if you change the direction of rotation. The propeller is set at the factory to turn counterclockwise (viewed from the hose side).

4.2 Example fitting options

(380 l/min | 100 bar net)

Calculated values

Flow rate	359.9 (B1) / 376.4 (B2) / 374.8 (B3) l/min
Final pressure	100.0 bar
Pressure loss	0.0 bar
Traction approx.	32 kg
Excess	20.1 (B1) / 3.6 (B2) / 5.2 (B3) l/min
Leakage	0.0 l/min

Assembly

- A = 2.0 mm
- B1 = 3 x 3.4 mm
- B2 = 6 x 2.5 mm
- B3 = 6 x 2.0, 3 x 2.1 mm
- S = 7 x 1.8 mm

Example B3

B3 in this case would be 6 x 2.0 mm and 3 x 2.1 mm. This means 2 x 2.0 mm and 1 x 2.1 mm per propeller arm.

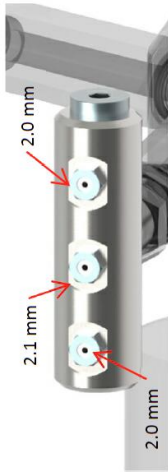

Figure 2 Example B3

Example B2

With B2, a nozzle insert is replaced with a blind plug.

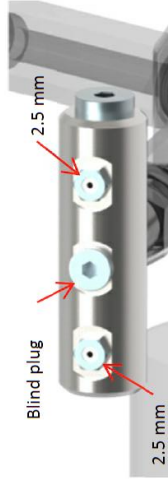

Figure 3 Example B2

Example B1

With B1, two nozzle inserts are replaced by blind plugs.

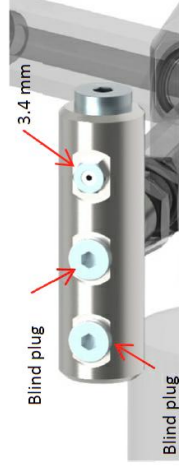
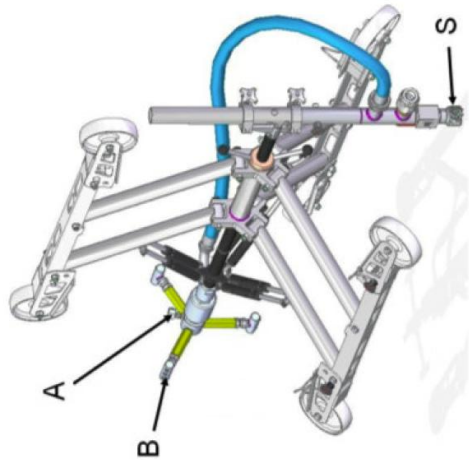

Figure 4 Example B1



6.2.3 Working without thrust

The thrust valve (item 8, page 11) can be opened or closed to operate the P360 with or without thrust. Working without thrust leaves more water for cleaning.

Replace the nozzles on the propeller to work without thrust. Use the JetCalc nozzle calculation program at <https://my.enz.com>.

Select whether you are operating with thrust in the second section of the P360 configuration in JetCalc.

The screenshot shows a configuration window with two sections. The first section, 'Einsatztyp', contains a list of radio button options: 'Keramik mit Nocken' (selected), 'Keramik', 'Stahl', 'Saphir', 'Saphir mit Strahlleitkreuz', and 'Andere'. Below this list is a text field 'Anderer Einsatztyp' followed by a percentage sign. The second section, 'Schub', contains two radio button options: 'Ohne' and 'Mit'. A red arrow points to the 'Ohne' option.

Figure 6 JetCalc

6.3 Drive modes

There are three modes for how the P360 is driven in the sewer. Regardless of the mode selected, the P360 is pulled from the exit manhole to the entry manhole via the truck’s connection hose. The modes differ in terms of how the P360 advances through the sewer from the entry manhole.

1. The thrust part drives the P360 through the sewer starting from the entry manhole.
 - Proximity protection on the propeller (standard)
 - Thrust valve open

2. The P360 is pulled from manhole to manhole. A pre-cleaning tool takes the hose to the exit manhole, where the hose is attached to the P360. The pre-cleaning tool returns to the truck on the surface.

- Proximity protection on the propeller (standard)
 - Thrust valve can be opened or closed
3. The P360 is pulled on a cable from the entry manhole to the exit manhole. Attach the supplied pulling equipment to the propeller for this mode. See **Section 7.7** on **page 34**.
 - Pulling equipment on propeller (Art. No. C366)
 - Thrust valve closed

6.4 Lubricating the spindle

1. Remove any grease residue from the spindle with a cloth.
2. Grease the spindle with high-performance grease (Art. No. 14.99008).
3. Open and close the skids at least once so that the fat is evenly distributed.

6.5 Replacing the connecting hose

1. Remove the defective connecting hose with an open-end wrench (41 mm). Apply counter-torque to the angle piece as needed.
2. Attach the replacement hose to the angle piece. Tighten the connection with the open-end wrench.
3. Move the handle and hose connector to the new hose if you are just changing the hose.

6.6 Other maintenance

Users may only perform the maintenance tasks described in this manual. The user may also replace the following parts:

- Hose belts (007.250075)
- Locking pin (007.250015-SET/007.250058-SET)
- Polyamide wheel (007.250052-SET)
- Accessories

Only the manufacturer's qualified specialists may perform other maintenance and service work.

6.7 Troubleshooting

6.7.1 Streaks on the pipe wall

Streaks on the pipe wall indicate that the P360 was pulled through the pipe too quickly or that the propeller was rotating too slowly. Perform the following to prevent streak formation:

- Advance the propeller nozzle through the pipe more slowly.
- Check whether the nozzle inserts are clogged.
- Install a larger nozzle insert on the rotational drive to increase the propeller's rotational speed. See **Section 6.2** on **page 19**.

6.7.2 Poor cleaning performance

Perform the following to improve cleaning performance:

1. Check whether the nozzle inserts are clogged.
2. Use the propeller extensions if the nozzle inserts are too far from the pipe wall. See **Section 7.4** on **page 31**.
3. Check whether the cleaning truck provides the minimum pressure and flow. Check whether the propeller nozzle is coordinated to the truck's parameters.

6.7.3 Propeller does not rotate

1. Check that the propeller can move freely.
2. Check the nozzle inserts on the rotational drive for clogs.
3. Check whether the cleaning truck provides the minimum pressure and flow. Check whether the propeller nozzle is coordinated to the truck's parameters.

6.7.4 No more forward movement

Potential causes:

- The slopes are too steep or the distance is too long. → Retract the nozzle and start cleaning from the other side. The nozzle can also be pulled. Use the pulling equipment (Art. No. C366) for this.
- The sewer has a slight curve. → Use a slightly smaller skid diameter. Ensure that the propeller cannot touch the pipe wall.
- The nozzle is stuck at an obstacle. → Carefully retract the propeller nozzle. Send a sewer pipe video camera through the sewer. If possible, rinse the obstacle out of the pipe with a standard nozzle. Otherwise, continue rinsing from the other side.









**CAUTION**

The nozzle can get caught. Do not pull too hard on the rinsing hose – you could damage the nozzle.

7 Technical specifications



Figure 7 P360 propeller nozzle

Article number		07.2500A/B
	BSPG connecting thread	1" 1 1/4"
	Rotating nozzles/bores	10 x M10
	Thrust jet	7 x M10
	Can use recycled water	Yes
	Weight	65 kg 143 lbs
	Application range	600 – 3000 mm 24 – 118 inch
	Dimensions	580 x 1996 mm 22.9 x 78.6 inch
	Min. flow rate at 100 bar (1450 psi)	250 L/min 66 US gpm
	Max. working pressure	200 bar 2900 psi

7.1 Drawings

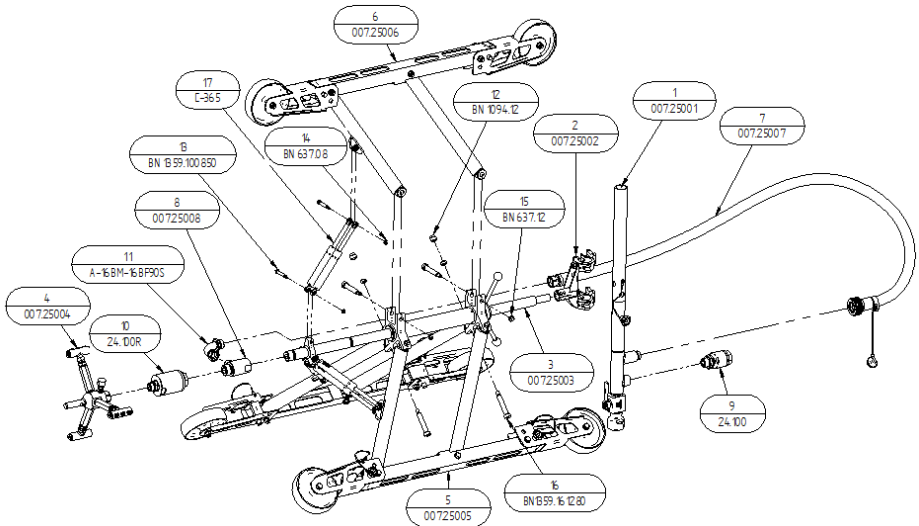

Drawing 1 P360 propeller nozzle

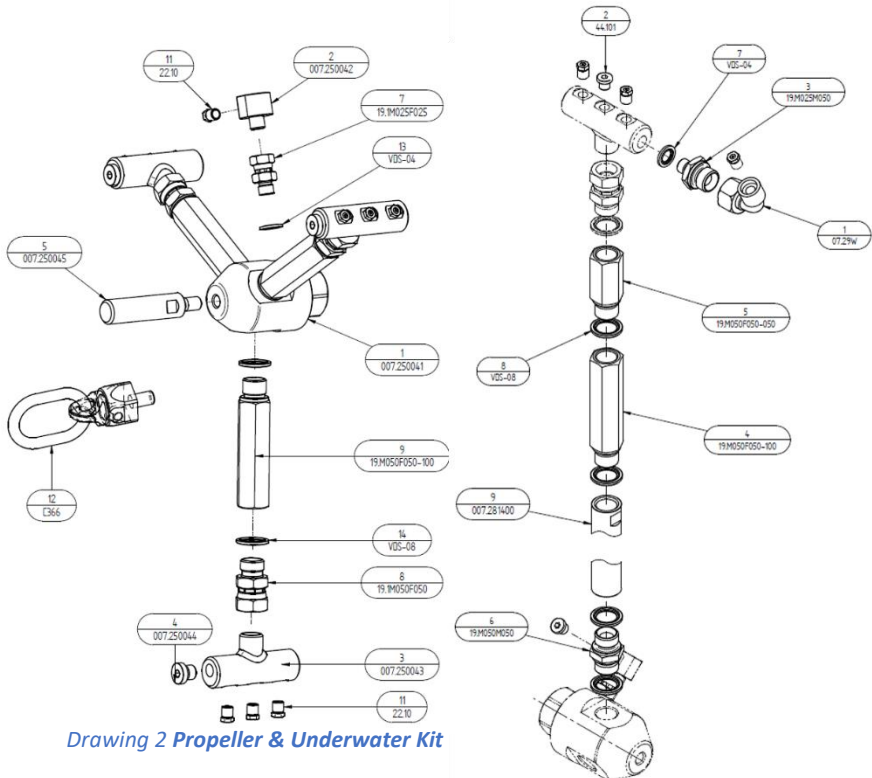

Drawing 2 Propeller & Underwater Kit

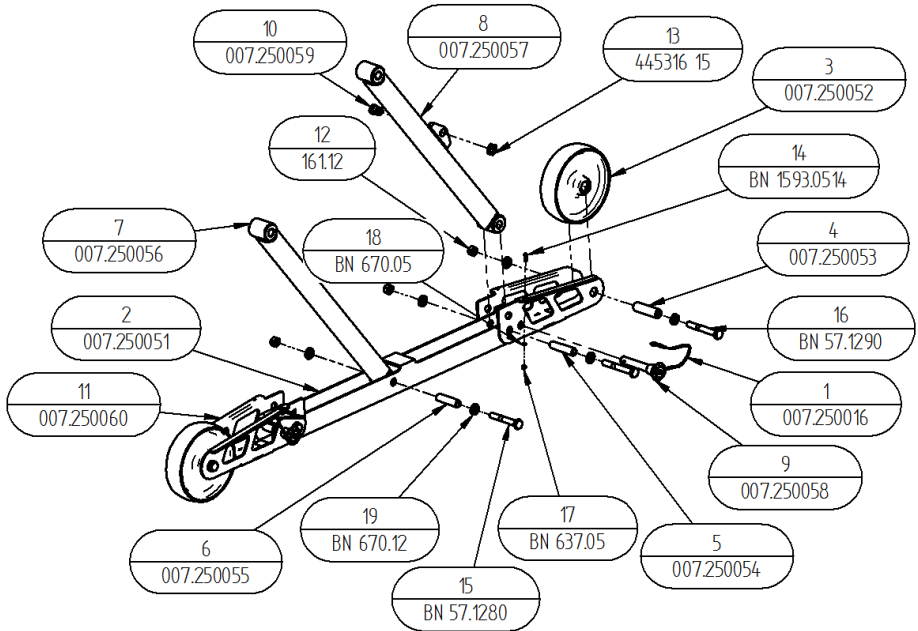

Drawing 3 007.25005 skid

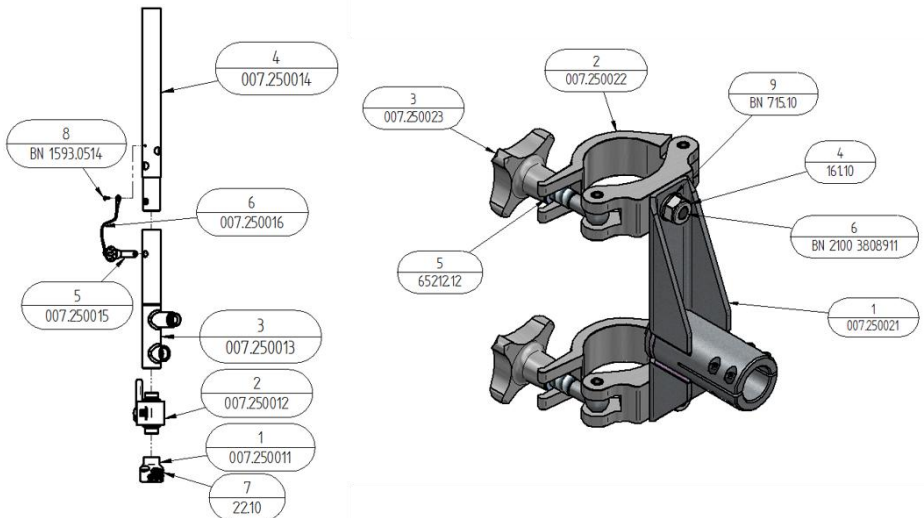

Drawing 4 007.25001 thrust part & 007.25002 thrust fastener

7.2 Setup methods

7.2.1 Setup in round, horseshoe, and rectangular profiles

In these profiles, the black wheel carrier of the P360 is on top. The thrust part hovers about 50 – 100 mm above the floor.



Figure 8 P360 in a round profile

7.2.2 Setup in an egg-shaped profile

In an egg-shaped profile, the black wheel carrier of the P360 is folded out and is on bottom. Install the thrust part flipped 180°. The thrust part hovers about 50 mm – 100 mm above the floor.



Figure 9 P360 in an egg-shaped profile

7.3 Adjusting the skids

7.3.1 Setting the skids for the pipe diameter

Turn the rotary lever to extend the P360 skids. Ensure there is about 50 mm of clearance to the top of the pipe so the equipment doesn't get stuck.

The force required for rotation is highest when the lever is at its minimum setting. In other words, the lever is easier to turn as it gets farther from the thrust part.



Figure 10 Center tube with rotary lever

7.3.2 Folding the wheel carriers out

Press the red button on the locking pin while pulling the locking pin. Fold the wheel carrier out. Insert the pins in the holes for the new setting. The wheel carriers do not need to be folded out in round profiles with diameters up to 1500 mm.

When working in an egg-shaped profile, only fold out the black wheel carriers. In all other profiles, position the wheel carriers as needed.



Figure 11 Wheel carrier folded out

7.4 Adjusting the propeller for the pipe diameter

A high-quality water jet is critical for optimal cleaning. The force of the water jet decreases as distance increases.

Propeller extensions shorten the distance between the nozzle inserts and the pipe wall, increasing the force of the water jet against the pipe wall.

The short propeller arms, which are installed as standard, are sufficient for cleaning round profile with diameters up to 1800 mm. Beyond this diameter, it is best to work with the supplied extension pipes.

Item	Qty	Name	Art. No.
1	3	Seal VDS-08 1/2"	VDS-08
2	3	Nipple G1/2" - G 1/2"	19.M050M050
3	3	Extension 1/2"f 1/2"f - 415 mm	007.281400

This extends the propeller diameter from 448 mm to 1107 mm. Install the extension tubes as shown in **Figure 12**.

There are additional options for configuring the propeller as needed. See **Table 1** on **page 33**.

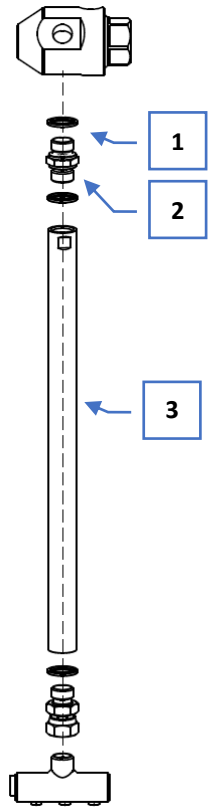

Figure 12 Exploded diagram of extension pipe



Tip:

The propeller arms can be set up outside of the sewer and then simply installed in the sewer.

7.5 Working underwater

Efficient underwater operation of the propeller nozzle requires the propeller arms to be set up so that the nozzle inserts are as close to the pipe wall as possible. The distance between the nozzle inserts and the pipe wall should be 50 – 100 mm. Use the Underwater Kit (Art. No. 007.25009). Drive elbows (Art.No. 07.29W) on each propeller end ensure that the propeller has sufficient driving force underwater. Installing the drive elbows at a 45° angle ensures the required drive underwater.

7.5.1 Installing the Underwater Kit

Perform the following to install the Underwater Kit:

1. Unscrew the nozzle insert from the rotational drive. Replace this with the supplied blind plug (Art. No. 44.101). Use Loctite 243 (Art. No. C192) when installing the blind plug.
2. Unscrew the middle nozzle insert from each nozzle head. Replace these with the supplied blind plugs (Art. No. 44.101). Use Loctite 243 (Art. No. C192) when installing the blind plugs.
3. Remove the blind plugs (Art. No. 007.250044) on the sides of the nozzle heads. Replace these with drive elbows (Art. No. 07.29W). Install the drive elbows at a 45° angle to the other nozzle inserts. Use the supplied O-ring (Art. No. VDS-04).
4. Install the nozzle insert removed during step 2 on the end of the elbow. Use Loctite 243 (Art. No. C192) for this.
5. The compound must cure for at least 24 hours.
6. Determine the inside diameter of the sewer. Determine the optimal propeller arm length using **Table 1** on **page 33**. Set up the propeller arms so you can just install them once in the sewer.



Figure 13 Nozzle head rebuild



CAUTION

Note the direction of rotation of the propeller. Orient the drive elbows (Art. No. 07.29W) such that their water jets spray the same direction as the original drive nozzle. The propeller turns counterclockwise, viewed from the hose side.

7.5.2 Parts list for configuring the propeller diameter

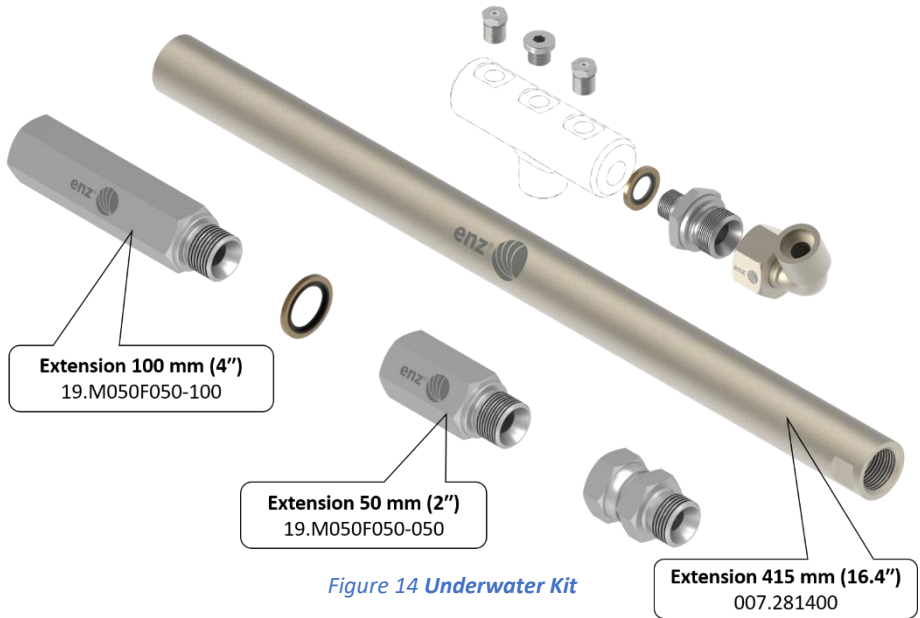

Figure 14 Underwater Kit

Propeller diameter	50 mm (2") extension(s)	100 mm (4") extension(s)	415 mm (16.4") extension(s)
448 mm 17.64 inch	0	3	0
553 mm 21.78 inch	3	3	0
653 mm 25.71 inch	0	6	0
758 mm 29.85 inch	3	6	0
1107 mm 43.59 inch	0	0	3
1212 mm 47.72 inch	3	0	3
1312 mm 51.66 inch	0	3	3
1417 mm 57.92 inch	3	3	3
1622 mm 63.86 inch	3	6	3

Table 1 Propeller diameter

7.5.3 Installing the thrust part and the connecting hose

1. Install the thrust part with the star grips. Ensure the thrust part will hover about 50 – 100 mm over the pipe floor.
2. Place the thrust rod extension (Art. No. 007.250014) in the thrust part. Leave this optional part off if the pipe diameter is small.
3. Hand-tighten the connecting hose to the top connection of the thrust part.
4. Open or close the thrust valve based on the drive mode. See **Section 6.3** on **page 22**.



CAUTION

Ensure all lock washers outside the pipe clamps are directly against the star grip. Otherwise, the thrust part is not secure and could come loose during operation.

7.6 Securing the hose

Secure the high-pressure hose with the attached hose belts (Art. No. 007.250075) when working in small diameters.

1. Inspect the connecting hose and replace it if it is damaged.
2. Ensure that the connecting hose cannot touch the sewer wall.
3. Ensure that the hose doesn't kink during operation.



CAUTION

If the connecting hose touches the pipe wall during operation, damage could result. Do not operate the P360 with a defective connecting hose.



7.7 Installing the supplied pulling eye





1. Remove the proximity protection (Art. No. 07.250045). Clean the threads.
2. Apply Loctite 243 to the threads of the pulling eye (Art. No. C366). Screw the pulling eye to the propeller head. The compound must cure for at least 24 hours.



Figure 15 Pulling eye (Art. No. C366)

8 Accessories

Figure	Article number	Name
	007.25009	Underwater Kit
	19.M050F050-050	50 mm extension
	19.M050F050-100	100 mm extension
	007.281400	415 mm extension
	19.M050M050	Nipple, 1/2"-1/2"
	007.25007	Hose assembly
	007.250015-SET	Locking pin, 16x50 set
	007.250058-SET	Locking pin, 16x70 set
	007.250075	Hose belt
	007.250052-SET	Polyamide wheel set

	<p>C366</p>	<p>Pulling eye M12</p>
	<p>C191</p>	<p>Oil Spray Bio</p>
	<p>14.99008</p>	<p>High-performance grease</p>
	<p>C192</p>	<p>Loctite 243</p>

10 Index

10.1.1 Figures

<i>Figure 1 Parts overview for P360</i>	11
<i>Figure 2 Operating principle of P360</i>	12
<i>Figure 3 Cordoned-off & identified work area</i>	14
<i>Figure 4 P360 being lowered into manhole</i>	15
<i>Figure 5 OIL SPRAY BIO, 500 mL</i>	19
<i>Figure 6 JetCalc</i>	22
<i>Figure 7 P360 propeller nozzle</i>	26
<i>Figure 8 P360 in a round profile</i>	29
<i>Figure 9 P360 in an egg-shaped profile</i>	29
<i>Figure 10 Center tube with rotary lever</i>	30
<i>Figure 11 Wheel carrier folded out</i>	30
<i>Figure 12 Exploded diagram of extension pipe</i>	31
<i>Figure 13 Nozzle head rebuild</i>	32
<i>Figure 14 Underwater Kit</i>	33
<i>Figure 15 Pulling eye (Art. No. C366)</i>	34

10.2 Drawings

<i>Drawing 1 P360 propeller nozzle</i>	27
<i>Drawing 2 Propeller & Underwater Kit</i>	27
<i>Drawing 3 007.25005 skid</i>	28
<i>Drawing 4 007.25001 thrust part & 007.25002 thrust fastener</i>	28



enz® technik ag
Schwerzbachstrasse 10
6074 Giswil, Switzerland
Phone +41 41 676 77 66
info@enz.com
www.enz.com