



IMC Recycling Milling cutters

14.100R

14.120R

14.150R



Operating Manual
English
March 25 | Version 1.3



Table of Contents

Table of Contents	2
Preface	4
Purpose of the document	4
1 Safety.....	5
1.1 Noncompliance with the safety information and its consequences	5
1.2 Target group	5
1.3 User requirements	5
1.4 Explanation of general safety instructions	6
1.5 Information provided in these operating instructions	6
1.6 Intended use.....	6
1.7 Safety warnings for modifications.....	7
1.8 Protective equipment for working in manholes, excavations, and sewer lines	7
1.9 General safety instructions	9
2 Legal	11
2.1 Copyright	11
2.2 Exclusion of liability	11
2.3 Warranty conditions.....	11
3 Recycling impact milling cutters.....	12
3.1 Introduction.....	12
3.2 Application	12
4 Installation.....	13
4.1 Installing the tools	13
4.2 Preparatory work	13
4.3 Setting up the work area	13
5 Operation.....	15
5.1 Basic function	15
5.2 Operating the tools	16
5.3 Cleaning plastic pipes	18
5.4 Cleaning pipes with minor damage	18
5.5 Completing work	18
5.6 Care after use	19
5.7 Troubleshooting	19
6 Maintenance.....	20
6.1 Maintenance after each use.....	20
6.2 Nozzle inserts	20
6.3 Replacing parts	21
6.4 Replacing a cutting tooth	22
6.5 Cam plates.....	23

6.6 Disposal and environmental protection26

7 Technical specifications.....27

7.1 14.100R.....27

7.2 14.120R.....28

7.3 14.150R.....29

7.4 Screw torques.....30

7.5 Cutting teeth30

7.6 Retrofitting to other diameters34

7.7 Turning impact on and off36

7.8 Working with a diamond crown drill bit.....38

8 Accessories39

8.1 Cutting teeth39

8.2 Retrofit kit40

8.3 Cutter heads40

8.4 Diamond crown drill bits40

8.5 Cages41

8.6 Miscellaneous.....41

9 Index.....43

9.1 Figures43

9.2 Tables43

Version	Revision	Date	Initials
1.0	Created	February 2024	bbi
1.1	Article number changed	August 24	bbi
1.2	Retrofit kit inserted	October 24	Bbi
1.3	Renewal of QR-Code, adjustment of the description of the cam plate	March 2025	lgo

Preface

Dear valued customer,

Thank you for the confidence and trust you've placed in us by purchasing one of our products.

We always appreciate suggestions and new design ideas. Your feedback will help us improve the design of our product and the associated documentation.

If you have any questions or suggestions, please contact our Customer Service Department.

enz® technik ag

Tel. +41 41 676 77 66

info@enz.com



Feedback form

www.enz.com/en/header/feedback

Person responsible for the documentation:

Bryan Bieri (Tech. Support / QM Manager)

We reserve the right to modify and further enhance our products without prior notice as a result of technological advances. Misprints reserved.

Purpose of the document

The purpose of this manual is to instruct you on how to use our product correctly, effectively, safely, and for its intended purpose. The user will be informed about risks, reasonably foreseeable misuse, and residual risks.



Important!

Read carefully before use.

Keep for later reference.

Please read this operating manual thoroughly before using the cleaning tool. Make sure that all employees who work with the product know how to use it correctly.

The operating manual must be available to all operating personnel at all times. It must be kept in an easily accessible place.

If the manual is misplaced or destroyed, a new copy can be requested from your nearest dealer or from the manufacturer directly.

1 Safety

1.1 Noncompliance with the safety information and its consequences

Disregarding these safety instructions may lead to accidents and severe personal injuries, material damage, and damage to the environment.

The manufacturer cannot be held responsible for any damages resulting from non-compliance with these instructions.

1.2 Target group

This manual is intended for all persons who will be involved in the assembly, start-up, and operation of the pipe cleaning tool.

1.3 User requirements

Personnel intending to assemble, start up and operate the tool must...

- Be familiar with the field of sewer maintenance work and possess the appropriate technical knowledge.
- Be trained and instructed appropriately in the use of the product.
Have read and understood the operating manual, in particular the section on "**Safety**"

If your personnel do not possess the necessary knowledge, they must be trained and instructed on it. If necessary, the pipe cleaning tool manufacturer can provide this instruction and training.

Only the maintenance and service activities described in this manual may be performed by users who have met the above-listed requirements. Any additional maintenance and service work may be performed only by qualified specialist personnel from the manufacturer.



Please refer to the section on "**Maintenance**".

1.4 Explanation of general safety instructions

The general safety instructions in this section provide information about potential residual risks, which are inherent to the product and may occur unexpectedly, despite the proper usage of the product.

In order to prevent personal injuries, material damage, and damage to the environment, all personnel working with this product must comply with these safety instructions. It is mandatory for said personnel to read and to understand the information provided in this section.

1.5 Information provided in these operating instructions



DANGER!

Noncompliance may lead to serious injury or **loss of life**.



WARNING!

Noncompliance may lead to serious injury and / or cause a long-term disability.



CAUTION!




Noncompliance may lead to injury and considerable material damage, financial loss or damage to the environment.



Information on the technically correct and efficient use of the product.

1.6 Intended use

The product is designed to clean the insides of pipes (sewer pipes). The following points must be followed to ensure proper use of the product:

-  The cleaning tool may be used only in pipes or pipe-like sewers. The profile to be cleaned must be free of leaks and surrounded by material.
-  The tool may be used on the following types of pipes:
 - PE pipes
 - Steel pipes
 - Concrete pipes
-  For use in pipes made of other material, please consult the manufacturer.

- ⚠ The product may be operated only in pipes with correctly installed and defect-free connections.
- ⚠ Cleaning areas (manholes, pipe branches etc.) need to be sufficiently secured during the operation, including during construction and cleaning work.
- ⚠ During the cleaning operation, **no** personnel are allowed inside the pipes or at either end of the pipes.
- ⚠ The maximum pressure indicated on the nozzle may **not** be exceeded.
- ⚠ Wastewater may **not** be drained into watercourses (creeks, rivers etc.).
- ⚠ The product must be inspected to ensure it is in proper working order before every start-up.
- ⚠ Defects must be rectified before start-up.
- ⚠ Use the tool only as intended. (Use only the correct wrench for nuts).
- ⚠ Secure the hose lines in such a way that they cannot become damaged during operation.
- ⚠ Only the accessories provided and approved by **enz® technik ag** may be used.

1.7 Safety warnings for modifications

No other changes or modifications to the pipe cleaning tool may be performed. Only parts authorized by the manufacturer may be used. The manufacturer is not liable for damage resulting from unauthorized changes to the product.

1.8 Protective equipment for working in manholes, excavations, and sewer lines

The employer must provide suitable personal protective equipment and ensure that it is worn by the employees during work.

In the following section, the protective equipment prescribed by Schweizerische Unfallversicherung SUVA (the Swiss Accident Insurance Organization) will be described.

For more information on this, refer to the brochure:

**Safe entry and working in manholes, excavations, and sewer lines
(in German, French & Italian)**

Order number: 44062.d

Suva
Schweizerische Unfallversicherungsanstalt
Arbeitsicherheit
Postfach, 6002 Lucerne, Switzerland
For information:
Phone +41 41 419 51 11
For orders:
www.suva.ch/waswo
Phone +41 41 419 58 51



Respirators

Self-contained respiratory equipment for spending time in dangerous atmospheres and for use during rescue operations.



Respirators

Self-rescue respiratory equipment (devices with compressed air tanks or regeneration devices) for working in sewers and for first aid for injured persons.



Rescue harness

Rescue harness or protective clothing with a loop sewn into the neck. During rescue, the rescue rope will be attached to the neck loop. Injured persons will be lifted out using a rescue lifting device with a self-actuating load brake.



Suitable working clothing

Leak-proof clothing protects the skin from becoming soiled and from possible infections. Visually conspicuous work clothing makes the employee more visible to traffic.



Appropriate footwear

Safety footwear should, in particular, have good grip and be slip-resistant and leak-proof (e.g. rubber boots).



Gloves

Appropriate gloves will protect you from hand injuries and contact with materials that could impair your health and from untreated water.



Hardhat

The hardhat will protect your head from falling objects and from bumping into fixed components and objects.



Hearing protection

If there is noise that could damage your hearing, you must wear, e.g. earmuffs with built-in headphones and microphone.



Eye protection

Your eyes should be protected against grit, sprayed dangerous substances, etc.



Lighting independent of the power grid

For example, you should carry a waterproof flashlight or wear a flashlight attached to your hardhat.

1.9 General safety instructions



Danger! | High-pressure water jets

Defects in or unintended use of the product could cause hazards due to pressurized water spray. Never remain in the channel during operation. Ensure that the product is in perfect condition before operation. Highly concentrated water jets can cause serious injury and could even sever limbs.



Danger! | Toxic vapors

There can be toxic vapours in sewer lines. Wear the prescribed protective equipment such as gas masks, gas warning devices and rescue harnesses. Inhaling toxic vapours or air that is contaminated with particles could be **fatal** or lead to serious injuries if the particles enter the lungs.



Warning! | Falling objects

Around open manholes, objects can fall down into the manhole and onto the people below. Never remain directly beneath the manhole opening when guiding the products in. Secure the manhole entrance against parts that could fall. Do not throw any tools or objects down into the manhole. Do not enter any manhole where there is a danger of falling. Personnel could become trapped.



Warning! | Chemical burns

There may be unidentified, corrosive, or otherwise harmful substances in the sewer line. Put on appropriate protective clothing. Use the protective equipment prescribed. Otherwise, you could suffer from chemical burns to your skin and eyes or become infected with pathogens.

**Warning! | Falls from height**

Open manholes are to be expected in the area where you will be working with the product. You must warn people about open manholes. Pay attention to where you are walking.

**Warning! | Hand injuries**

In case of tampering with the product, there is a risk of hand injury due to getting caught or abrasion. Wear gloves during work. Pay attention to where you grip the product. Always have sufficient people carry heavy, or over-sized, equipment. Consequences can include crushing injuries, abrasions or even the loss of a limb.

**Caution! | Sharp objects**

If the product is tampered with, there is a risk of hand injuries due to sharp edges. Wear gloves during work. Pay attention to where you grip the product. Consequences can include cutting injuries to your hands or other parts of your body.

**Caution! | Trip hazards**

Lines and other objects are to be expected on the ground in the area around where the product is being used. Pay attention to where you are walking. Keep the area of use tidy. Tripping and falling could cause serious injuries.

2 Legal

2.1 Copyright

This manual shall not be duplicated partially or in its entirety without the prior written permission of **enz® technik ag**. It shall not be photocopied, reproduced, translated, or converted into an electronic or machine-readable format.

©2025 enz® technik ag, 6074 Giswil, Switzerland.
All rights reserved.

2.2 Exclusion of liability

The manufacturer is not liable for damage that:

- Is caused as a result of unauthorized changes to the product.
- Is caused by not following the safety instructions.

2.3 Warranty conditions

In accordance with our sales and delivery conditions, we offer a warranty. However, the warranty is voided if:

- The product is used under conditions that are not permitted by us.
- Replacement and accessory parts that are not original replacement and accessory parts from **enz® technik ag** are used.
- If there is damage due to:
 - Improper use
 - Not following the operating manual
 - Unsuitable operating equipment
 - Incorrect or improper routing of the hose or pipelines
 - Unauthorized changes or modifications to or conversions of the product.

3 Recycling impact milling cutters

3.1 Introduction

enz[®] recycling impact milling cutters are designed for milling extremely hard deposits in pipes. The modular construction makes it possible to work with multiple diameters from one base structure.

Carbide or diamond teeth are used based on the hardness of the deposits.

3.2 Application

enz[®] recycling impact milling cutters can be operated with fresh or recycled water and are suitable for milling out the following deposits:

- Limescale
- Concrete
- Plastic
- Wood
- Injections
- Etc.



CAUTION

Impact milling cutters may only be operated by trained employees.
Failure to comply leads to major damage to pipes and tools.

4 Installation

4.1 Installing the tools

Tools are delivered operationally ready and are set up at the factory for milling with impact. After unpacking, check the delivery for completeness.







4.2 Preparatory work

It is advisable to clarify some points before use. Knowledge of the following points is helpful during preparations and when adjusting the impact milling cutter:

- Layout of the lines. → Only straight lines can be milled.
- Inner diameter of the sewer where work will be performed.
- Material and condition of the sewer where work will be performed.
- Type of material to be removed in the pipe (limescale, concrete, etc.).
- Percent coverage of deposits.
- Planned flushing direction. → We recommend that you mill against the direction of flow.
- Slopes in the sewer where work will be performed.
- Sewer access points. → The first 40 cm (15 inch) of the pipe must be clear.

4.3 Setting up the work area

Perform the following before working with the impact milling cutter:

-  Set up barriers and safety equipment (warning signs, safety barriers, etc.).
-  Block off and secure the work area such that there is no risk of falling or of danger from traffic.
-  Obtain information regarding the wastewater entering the manhole (chemicals, gas, vapors, etc.).
-  Measuring instruments such as explosive gas meters, oxygen meters, and gas warning devices must be readily available.
-  Use a cutter with a suitable application diameter. This can be verified in the technical specifications, starting on page 27.
-  The layout of the lines (sewer maps) must be known before starting work to prevent the cutter from emerging at a pipe end. Support personnel must monitor possible emerging points.




-  Have the customer sign the liability waiver to protect against claims for damages.
-  For heavy tools, a tripod winch is required to lower the cutter into the man-hole. Do not lower the cutter on the hose.
-  Trained personnel who are familiar with milling work must be available for the milling project.



Figure 1 Cordoned-off & identified work area



Reduce the thrust when working in the direction of flow. See Section 6.2 on page 20.

5 Operation

5.1 Basic function

The recycling impact milling cutter is guided through the pipe via the skids (a). The thrust nozzles (b) generate thrust and propel the cutter forward through the pipe. The cutter head (c) is driven by the rotating nozzles (d). The carbide teeth (e) remove deposits at a rate of 600 – 3000 pulses per minute.

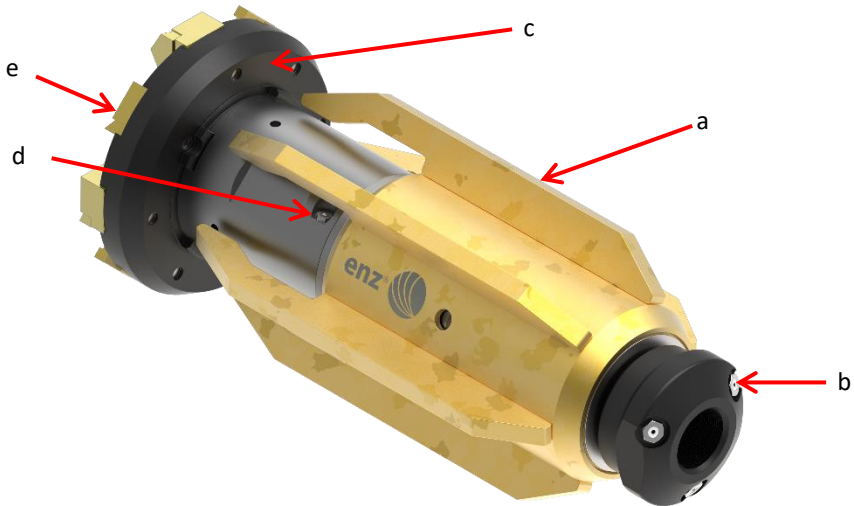


Figure 2: Basic function

The three thrust nozzles (b) can be replaced based on the application. The thrust nozzles control the contact pressure and the cutter's forward glide. Prepare various nozzle inserts for the thrust before the milling project. The procedure for replacing the nozzle inserts is described in Section 6.2.1 on page 20.

With the right impact milling cutter setting for the respective application, you can work faster and more efficiently.



Usually only the thrust nozzles need to be adapted to the application.

5.2 Operating the tools

1. Use a standard nozzle to flush all loose material out of the pipe before milling. Gravel may impair the milling process and damage the impact milling cutter's teeth.
2. Use a camera to survey the condition of the pipes and general parameters.
3. Check all screws with a torque wrench per page 30. Guide the impact milling cutter into the pipe.
4. Push the cutter into the pipe to at least half its length.
5. Allow the impact milling cutter to travel into the pipe at around 80 bar (1100 psi). Ensure that the cutter head does not rotate too fast.
6. As soon as the cutter reaches the deposit, slowly increase the pressure at the impact milling cutter to 100 bar (1450 psi).
7. Hold the high-pressure hose in your hand and feel its vibrations during milling. As soon as you stop feeling vibrations, pull the cutter back slightly so the cutter head starts rotating again. Then carefully let the impact milling cutter glide forward into the deposit.
8. Stop milling after two minutes and pull the cutter back at around 50 bar (700 psi). Check all the teeth and tighten them with a torque wrench per page 30.
9. Before resuming milling, use a camera to check the progress and to check the pipe for damage.
10. Push the impact milling cutter back into the pipe and continue milling.
11. Check the progress after one hour. To do so, remove the cutter from the pipe and check the progress with a camera. Also check the teeth for wear. Use a torque wrench to tighten the screws of the teeth and cutter head per the instructions on page 30. Perform this inspection hourly.



When possible, work against the direction of flow so the flow of water in the sewer is not interrupted.

5.2.1 Operating the tool in the direction of flow

The water must be pumped out to work in a downward sloping pipe where the water cannot flow toward the tool. This is the only way to operate the impact milling cutter efficiently. If the water in the sewer increases, the impact force will continually decline. You will recognize this by the decreasing vibration of the hose.

5.2.2 Vibrations can't be felt

With a steep incline or excessive distance, the hose vibrations will be so weak that they almost can't be felt. In this case, it's helpful for a second worker to go to the next manhole so they can observe for milling noise and escaping water. Impact noises confirm good milling operation.

**CAUTION**

Only use the impact milling cutter in straight pipes. Failure to comply could result in considerable damage.

**CAUTION**

Use the correct cutter diameter for the pipe. Failure to comply could result in damage to the pipe wall and tool.

**CAUTION**

The optimal operating pressure at the impact milling cutter is 100 bar (1450 psi). Ensure that the cutter head does not rotate too fast. Damage to the pipe or tool could result.



Suction the pipe upon insufficient impact force of the cutter. This reduces resistance and improves cutter efficiency.



If water builds up behind the cutter, pull the impact milling cutter back about 0.5 m and pause work until the water has drained.



Note that the thrust nozzles usually have to be adapted for operation in the direction of flow at a steep incline.



Use a flex guide, protective sleeve, or roller guide to protect the hose from wear caused by rough surfaces. These devices extend the service life of the hose considerably.

5.3 Cleaning plastic pipes

5.3.1 PE pipes

Set the cutting teeth on the outside ring inward to avoid damaging PE pipes. To do so, remove the screws of the outside cutting teeth and set the teeth inward. Tighten the screws to 38 Nm.

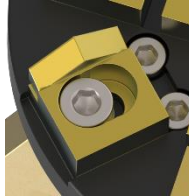


Figure 3: *Tooth position inward for plastic pipes*

5.3.2 PVC pipes

PVC pipes may only be milled if they are embedded in concrete. If this condition is met, use the same procedure as for milling in PE pipes.

5.4 Cleaning pipes with minor damage

Pipes with minor damage usually have cracks in the pipe wall. Inform the customer or the appropriate authorities if you notice cracks in the pipe wall.

Use extreme caution when working with pipes with minor damage. Use the tool at your own risk. **enz® technik ag** waives all liability.



CAUTION

When cracks are washed out, pipe fragments can break off, and the material surrounding the pipe may be washed out. If in doubt, do not use the cutter. The sewer could collapse.



Whenever possible, do not use impact in damaged pipes. See Section 7.7 on page 36.

5.5 Completing work

Check the clean pipe with a camera. Look in particular for damage and for liquids escaping into the environment. If necessary, scrape out the remaining margins of deposits with a chain scraper.

5.6 Care after use

Perform the following after using the impact milling cutter:

- Rinse the impact milling cutter with fresh water.
- Spray the entire impact milling cutter with OIL SPRAY BIO (Art. No C191). Then turn the cutter head manually several times.
- Check the carbide teeth for signs of wear and replace consumed carbide teeth.
- Tighten all screws per page 30.

5.7 Troubleshooting

5.7.1 The cutter head does not move

1. Pull the impact milling cutter back about 20 cm (8 inch).
2. Shake the water hose until the impact mechanism releases and the cutter head can freely rotate again.
3. Let the impact cutter glide up to the deposit slowly and continue milling.

5.7.2 The cutter head repeatedly stops

The thrust is too high. Reduce the thrust. To do so, replace the thrust nozzle inserts with ones of a diameter 0.2 mm smaller. See Section 6.2.1 on page 20.

It is sometimes helpful just to slightly tension the high-pressure hose to relieve the cutter head.

5.7.3 Insufficient impact force

You can detect insufficient impact force by the weak vibration of the high-pressure hose. See Section 6.5 on page 23.

5.7.4 Impact milling cutter moves upward

If the deposit layer is thin, the cutter can glide up onto the deposit and cut into the pipe ceiling. To prevent this, set the cutting teeth on the outside ring outward. Once the deposit has been cut into, place the cutting teeth back in neutral position.

6 Maintenance

Users with the necessary expertise may perform the maintenance and service tasks described in this operating manual.

6.1 Maintenance after each use

1. Check the nozzle inserts for blockage.
2. Check the tool – particularly the teeth – for wear. Replace defective parts.
3. For corrosion protection and care, treat the tool with OIL SPRAY BIO (Art No. C191).



Figure 4 OIL SPRAY BIO, 500 mL

6.2 Nozzle inserts

Regularly inspect the nozzle inserts. Wear depends on the degree of contamination of the water used. If recycled water is used, inspect the nozzle inserts daily and clean them if necessary.



CAUTION

Worn nozzle inserts impair cleaning results and increase risk when working with high pressure. Inspect the nozzle inserts daily if recycled water is used. Failure to comply could result in damage to the pipe system and tool.

Use JetCalc to determine the diameter of the nozzle inserts if you do not know it.

6.2.1 Replacing nozzle inserts

1. Clean the nozzle insert and heat it with the gas torch (Art. No C158) for about ten seconds.
2. Remove the nozzle insert with a socket wrench.
3. Clean and degrease the threaded hole and the new nozzle insert. You can use acetone to do this.
4. Coat the nozzle insert threads with Loctite 243 (Art. No. C192).
5. Screw the nozzle insert into the tool body with the socket wrench as far as it will go.
6. The compound must cure for at least 24 hours.

**CAUTION**

Only replace damaged nozzle inserts with identical nozzle inserts of the same diameter. If the tool is not correctly outfitted, the tool or the pipe can be damaged.

6.3 Replacing parts

A qualified user can replace all parts that are fitted during installation and the following additional parts:

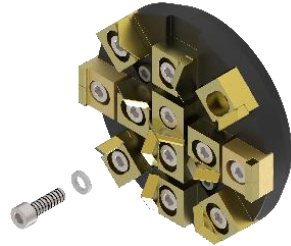
- Cutting teeth and cutter heads
- Nozzle inserts
- Cages
- Impact disks
- Accessories described in this operating manual

Further maintenance and service work may only be performed by the manufacturer's technicians.

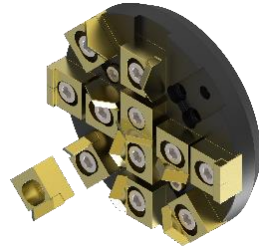
6.4 Replacing a cutting tooth

Cutting teeth are wear parts. They must be replaced periodically. Wear depends on the hardness of the material to be milled. Cutting teeth are positioned based on the deposit and the pipe material. See Section 7.5 on page 30.

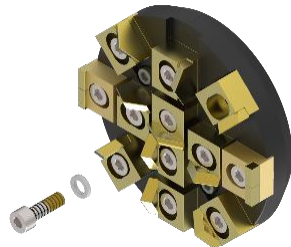
1. Remove the cylinder-head screw together with the Nord-Lock washer.



2. Remove the old cutting tooth and clean the contact surface.



3. Install the new cutting tooth in the desired position per page 30. Grease the threads of the cylinder-head screw and screw it in with the Nord-Lock washer.



4. Tighten the cylinder-head screw to **38 Nm**.

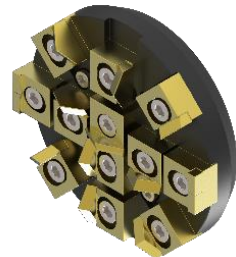


Figure 5: Replacing a cutting tooth

6.5 Cam plates

Cam plates (Art. No.14.KW05) are wear parts. They must be replaced periodically (about every 30 hours or when the stroke is $< 2 \text{ mm}$ ($< 0.08 \text{ inch}$)). The degree of wear varies greatly. It depends on the demand placed on the impact milling cutter.

6.5.1 Checking the cam plates

To check the cam plates, press the cutter head to the rear and slowly rotate it by hand. This causes the cam plates to move the cutter head back and forth. This stroke must be at least 2 mm ($< 0.08 \text{ inch}$). If the stroke is smaller, the cam plates are worn and must be replaced.

6.5.2 Replacing the cam plates

1. Remove the eight cylinder-head screws. Remove the cutter head.



2. Remove the center screw, the cover, and the disk springs.



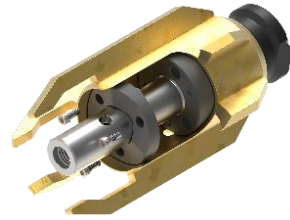
Notice

The disk springs must be replaced.

3. Remove the cutter hub.



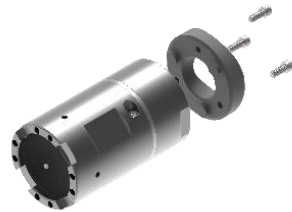
4. Remove the three cylinder-head screws and pull the cam plates off the cutter shaft.



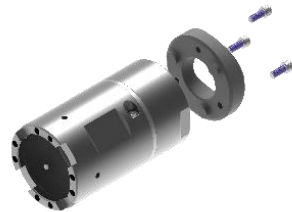
5. Coat the cylinder-head screws with Loctite 243 (Art. No. C192). Put the new cam plates in place. Tighten the screws to **12 Nm**.



6. Remove the three cylinder-head screws and pull the cam plates off the hub.



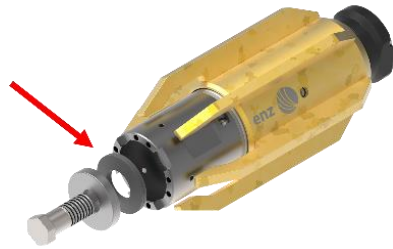
7. Coat the cylinder-head screws with Loctite 243 (Art. No. C192). Put the new cam plates in place. Tighten the screws to **12 Nm**.



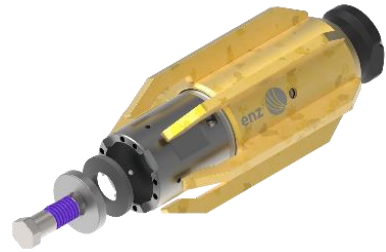
8. Place the cutter hub on the cutter shaft.



9. Place the cover and two new disk springs on the cutter shaft.



10. Coat the center screw with Loctite 243 (Art. No. C192). Tighten it to **180 Nm**.



11. Clean the contact surfaces of the cutter head and the hub. Put the cutter head in place. Coat the cylinder-head screws with Loctite 243 (Art. No. C192). Screw them in.



12. Tighten the cylinder-head screws to **12 Nm** with a torque wrench. The compound must cure for at least 24 hours.



Figure 6: Replacing the cam plates



CAUTION

The disk springs must also be replaced when replacing the cam plates. Failure to comply can lead to major damage to the cutter shaft.

6.6 Disposal and environmental protection

The tools do not require any special disposal procedure, and they can be disposed of with other scrap metal.

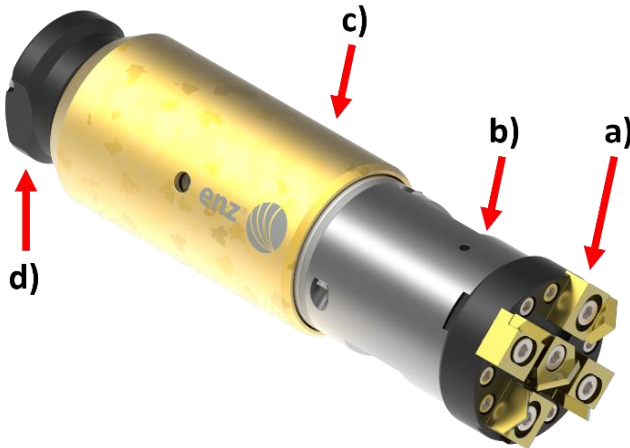
Only clean pipes for which the composition of the wastewater is known (industrial wastewater in particular). Chemicals and other toxic substances shall never be allowed to flow through defective pipes and enter the environment.

Report defective pipes or leaking substances to the supervisory body or appropriate authorities.

Do not use excessive water. This helps conserve natural resources.

7 Technical specifications

7.1 14.100R



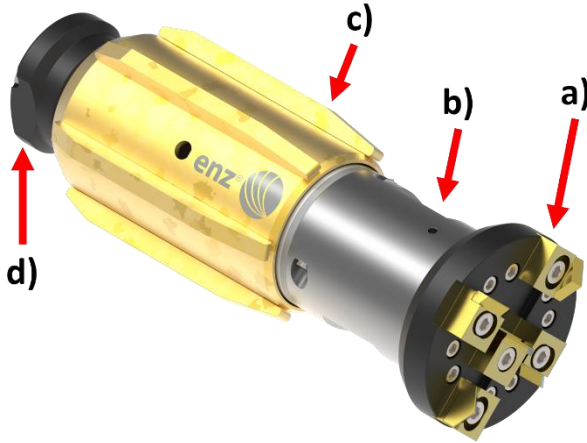
- a Cutter head
- b Hub
- c Cage
- d Thrust piece

7.1.1 Specifications

	Connection thread BSPP	1"
	Rotating nozzles/bores	3 x M8
	Thrust jet	3 x M10
	Can use recycled water	YES
	Weight	12.3 kg 27.1 lbs
	Application range	100 mm 4 inch
$\varnothing \times L$	Dimensions	90 x 350 mm 3.5 x 13.8 in
	Min. flow rate at 100 bar (1450 psi)	100 L/min 26 US gpm
	Maximum working pressure	150 bar 2100 psi

Table 1: Technical specifications, 14.100R

7.2 14.120R



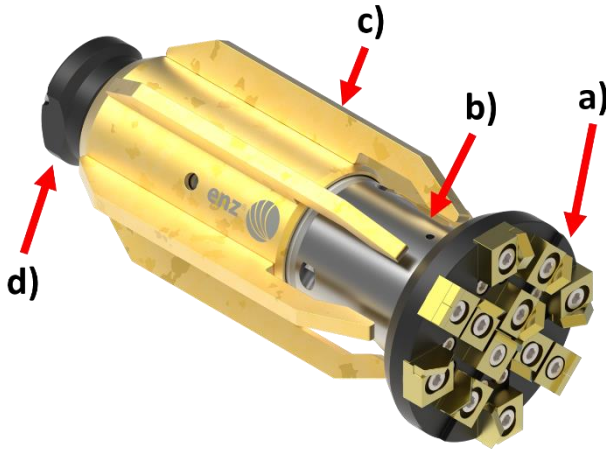
- a Cutter head
- b Hub
- c Cage
- d Thrust piece

7.2.1 Specifications

	Connection thread BSPP	1"
	Rotating nozzles/bores	3 x M8
	Thrust jet	3 x M10
	Can use recycled water	YES
	Weight	13.7 kg 30.2 lbs
	Application range	120 mm 5 inch
	Dimensions	112 x 350 mm 4.4 x 13.8 in
	Min. flow rate at 100 bar (1450 psi)	120 L/min 32 US gpm
	Maximum working pressure	150 bar 2100 psi

Table 2: Technical specifications, 14.120R

7.3 14.150R



- a Cutter head
- b Hub
- c Cage
- d Thrust piece

7.3.1 Specifications

	Connection thread BSP	1"
	Rotating nozzles/bores	3 x M8
	Thrust jet	3 x M10
	Can use recycled water	YES
	Weight	16.3 kg 35.9 lbs
	Application range	150 mm 6 inch
	Dimensions	136 x 350 mm 5.4 x 13.8 in
	Min. flow rate at 100 bar (1450 psi)	150 L/min 40 US gpm
	Maximum working pressure	150 bar 2100 psi

Table 3: Technical specifications, 14.150R

7.4 Screw torques

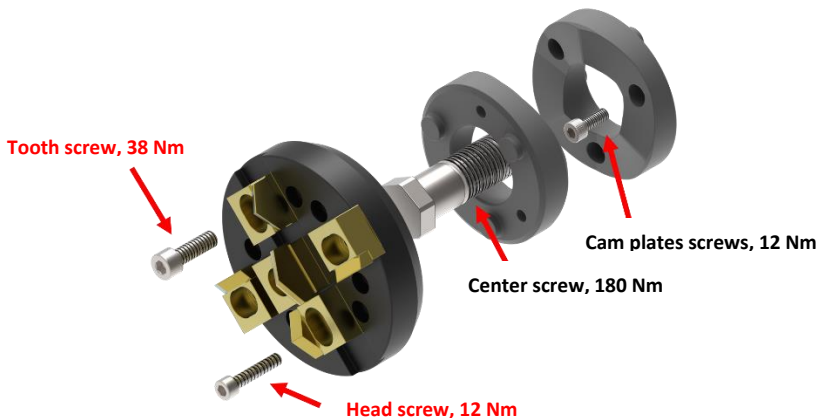


Figure 7: Tightening torques, 14.100 – 14.150



CAUTION

Check all torques in **red** with a torque wrench at the start of work, after two minutes, and then hourly. Failure to comply can lead to cutter damage or loose components.

7.5 Cutting teeth

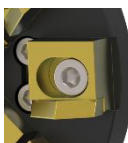
7.5.1 Tooth position on the outside ring



In the default setup, the universal cutting tooth (Art. No. 15.ZU) is in the neutral position.



In cast, steel, and concrete pipes, the universal cutting tooth (Art. No. 15.ZU) can be installed outward in exceptional cases.



In plastic pipes, the universal cutting tooth (Art. No. 15.ZU) is installed inward so the pipe wall is not damaged.

Table 4: Tooth positions on the outside ring

7.5.2 Setup for limescale deposits

The cutter head is equipped with a center tooth (Art. No. 15.Z1) and universal cutting teeth (Art. No. 15.ZU) in neutral position.

For the 14.150R, two circumferential teeth (Art. No. 15.ZHU) are also installed.

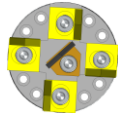
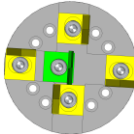
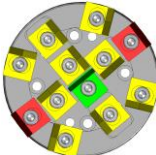
Figure	15.ZU	15.ZHU	15.Z1	15.Z1-100
<p>14.100</p> 	4			1
<p>14.120</p> 	4		1	
<p>14.150</p> 	9	2	1	

Table 5: Cutter head setup for limescale deposits

7.5.3 Setup for limescale deposits in a plastic pipe

To mill limescale deposits in plastic pipes, the universal cutting teeth (Art. No. 15.ZU) on the outside ring are installed inward. The two (Art. No. 15.ZHU) circumferential teeth for the 14.150R are replaced with (Art. No. 15.ZU) universal cutting teeth.



Always work without impact in a plastic pipe or in other fragile pipes. Follow the conversion instructions on page 36.

7.5.4 Setup for wood and plastic deposits

Use the special impact milling tooth for plastic (Art. No. 15.ZU-GSL) to mill wood and plastic deposits in a pipeline. These teeth have an additional cutting angle and are installed in the neutral position everywhere.

For the 14.150R cutter, both (Art. No. 15.ZHU) circumferential teeth are replaced with (Art. No. 15.ZU-GSL).

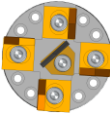
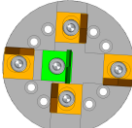
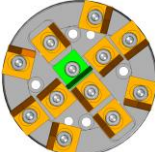
Figure	15.ZU	15.ZU-GSL	15.Z1	15.Z1-100
14.100 		4		1
14.120 		4	1	
14.150 		11	1	

Table 6: Cutter head setup for wood and plastic deposits



Always work without impact for wood or plastic deposits. Follow the conversion instructions on page 36.

7.5.5 Setup for concrete deposits

For extremely hard deposits, such as concrete, install diamond teeth (Art. No. 15.ZD) if the impact milling cutter’s performance is insufficient with universal cutting teeth (Art. No. 15.ZU). The diamond teeth are installed along the entire outside ring.


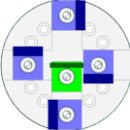
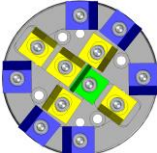
Figure	15.ZU	15.ZD	15.Z1	15.Z1-100
14.100 		4		1
14.120 		4	1	
14.150 	5	6	1	

Table 7: Cutter head setup for concrete deposits



To prevent the cutter from moving upward with a gradually rising concrete deposit, set the cutting teeth on the outside ring outward. After cut-in, put the cutting teeth back in neutral position.

7.6 Retrofitting to other diameters

100-series recycling impact milling cutters can be retrofitted to three different diameters. To retrofit the cutter, the skirts and cutter head must be converted. enz® offers complete retrofit kits for this.

Diameter	Name	Article number
100 mm / 3.9 inch	Retrofit kit from 14.1xxR to 14.100R	14.100KR-KIT
120 mm / 4.7 inch	Retrofit kit from 14.1xxR to 14.120R	14.120KR-KIT
150 mm / 5.9 inch	Retrofit kit from 14.1xxR to 14.150R	14.150KR-KIT

Table 8: Retrofit kit overview

1. Remove the eight cylinder-head screws. Remove the cutter head.



2. Remove the thrust part.



3. Remove both set screws from the cage.



4. Pull the disk springs and cage off toward the rear.



5. Slide the new cage with the desired diameter onto the cutter shaft.



6. Slide the disk springs onto the cutter shaft and coat the threads of the thrust piece with Loctite 243 (Art. No. C192). Set the thrust piece in place and tighten it down.



7. Coat both set screws with Loctite 243 (Art. No. C192) and tighten down the cage.



8. Clean the contact surfaces of the cutter head and the hub. Put the cutter head in place. Coat the screws with Loctite 243 (Art. No. C192) and screw them in.



- Torque the cylinder-head screws to **12 Nm**. The compound must cure for at least 24 hours.



Figure 8: Replacing the cutter head

7.7 Turning impact on and off



Figure 9 Spacers, 14.D

The cutter is shipped with impact on by default. This might need to be deactivated, depending on the deposits or the pipe material.

Two spacers are needed to deactivate impact. These are sold as a set under Art. No. 14.D.

- Remove the eight cylinder-head screws. Remove the cutter head.
- Remove the center screw, the cover, and the disk springs.



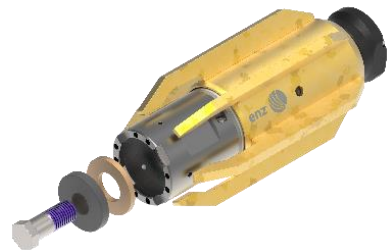
3. Remove the hub.



4. Install the larger spacer (Art. No. 14.D). Put the hub back on.



5. Install the smaller spacer (Art. No. 14.D) instead of the two disk springs. Coat the center screw with Loctite 243 (Art. No. C192) and tighten it to **180 Nm**.



6. Clean the contact surfaces of the cutter head and the hub. Put the cutter head in place. Coat the cylinder-head screws with Loctite 243 (Art. No. C192) and screw them in.



7. Torque the cylinder-head screws to **12 Nm**. The compound must cure for at least 24 hours.



Figure 10: Turning impact on and off

7.8 Working with a diamond crown drill bit

Diamond crown drill bits remove shorter elements such as rebar and inlet connections. There is a specific diamond crown drill bit for every pipe diameter. Refer to the diameter specifications in Section 8.4.

7.8.1 Installing a diamond crown drill bit

1. Only use a diamond crown drill bit with impact off. Install the spacers in the kit (Art. No. 14.D) per the instructions on page 36.

2. Remove the cylinder-head screws for all cutting teeth and remove the teeth.

3. Grease the hex screws in the kit and install the diamond crown drill bit. Screw in the hex screws together with the Nord-Lock washers and tighten them to **38 Nm**.

4. Perform the procedure in the reverse sequence to revert the assembly.

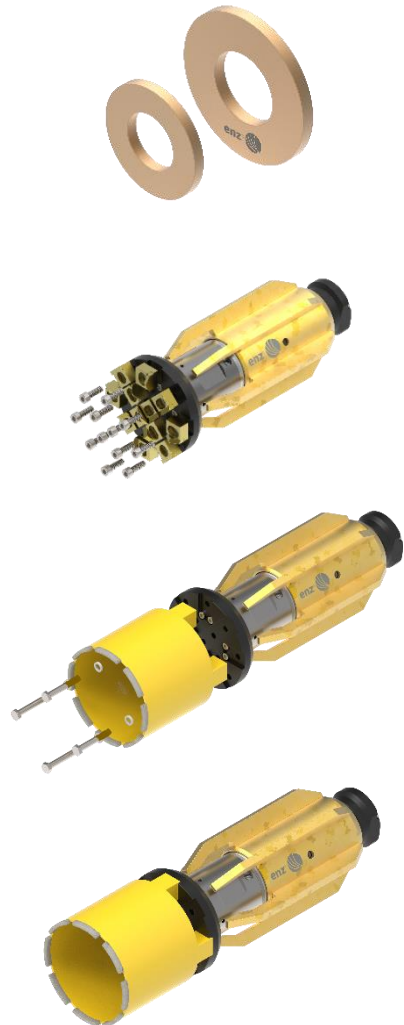


Figure 11: Installing the diamond crown drill bit

8 Accessories

8.1 Cutting teeth

Figure	Article number	Name	Application
	15.ZU	Universal tooth	14.100R – 14.150R
	15.ZHU	Circumferential teeth	14.150R
	15.ZU-GSL	Impact milling tooth for plastic	14.100R – 14.150R
	15.Z1	Impact cutter tooth for center	14.120R – 14.150R
	15.Z1-100	Impact cutter tooth, center	14.100R
	15.ZD	Diamond cutting tooth	14.100R – 14.150R
	1419.0825	Screw, M8	14.100R – 14.150R
	65212.08	Nord-Lock washer	14.100R – 14.150R

Table 9: Cutting tooth accessories

8.2 Retrofit kit

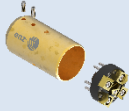


Figure	Article number	Name	Application
	14.100KR-KIT	Retrofit kit from 14.1xxR to 14.100R	14.100R
	14.120KR-KIT	Retrofit kit from 14.1xxR to 14.120R	14.120R
	14.150KR-KIT	Retrofit kit from 14.1xxR to 14.150R	14.150R

Table 10: *Retrofit kit*

8.3 Cutter heads

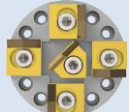

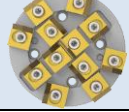

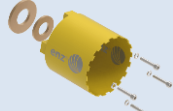
Figure	Article number	Name	Application
	14.100K	Impact milling cutter head with teeth, 100 mm	14.100R
	14.120K	Impact milling cutter head with teeth, 120 mm	14.120R
	14.150K	Impact milling cutter head with teeth, 150 mm	14.150R
	1420.0640	Screw, M6	14.100R – 14.150R

Table 11: *Cutter head accessories*

8.4 Diamond crown drill bits

Figure	Article number	Name	Application
	14.100D	Diamond crown drill bit	14.100

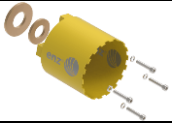
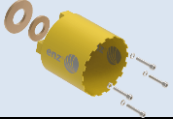
	14.120D	Diamond crown drill bit	14.120
	14.150D	Diamond crown drill bit	14.150

Table 12: Diamond crown drill bit accessories

8.5 Cages

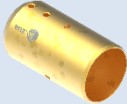



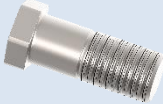


Figure	Article number	Name	Application
	0014.1004R	Cage, ø 100 mm	14.100R
	0014.1204R	Cage, ø 120 mm	14.120R
	0014.1504R	Cage, ø 150 mm	14.150R
	617.1025	Set screw for cage installation	14.100R – 14.150R

Table 13 Cage accessories

8.6 Miscellaneous

Figure	Article number	Name	Application
	0014.221554	Center screw	14.100R – 14.150R
	14.KW05	Cam plates, 5 mm	14.100R – 14.150R
	0014.0616T	Cylinder-head screws for cam plates	14.K05


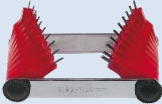
	14.T1	Disk spring, quenched and tempered, 3.5 mm	14.100R – 14.150R
	14.D	Spacers	14.100R – 14.150R
	0014.1503	Cover	14.100R – 14.150R
	20141.08SS	Nord-Lock wedge lock washer, M8	14.100R – 14.150R
	14.99001	Torque wrench (12 – 180 Nm)	
	C191	OIL SPRAY BIO 500 mL	
	C192	Loctite 243 50 mL	
	C200	Nozzle gauge 0.45 – 1.50 mm	
	C201	Nozzle gauge 1.50 – 3.00 mm	

Table 14: Miscellaneous accessories

9 Index

9.1 Figures

<i>Figure 1 Cordoned-off & identified work area</i>	14
<i>Figure 2: Basic function</i>	15
<i>Figure 3: Tooth position inward for plastic pipes</i>	18
<i>Figure 4 OIL SPRAY BIO, 500 mL</i>	20
<i>Figure 5: Replacing a cutting tooth</i>	22
<i>Figure 6: Replacing the cam plates</i>	25
<i>Figure 7: Tightening torques, 14.100 – 14.150</i>	30
<i>Figure 8: Replacing the cutter head</i>	36
<i>Figure 9 Spacers, 14.D</i>	36
<i>Figure 10: Turning impact on and off</i>	37
<i>Figure 11: Installing the diamond crown drill bit</i>	38

9.2 Tables

<i>Table 1: Technical specifications, 14.100R</i>	27
<i>Table 2: Technical specifications, 14.120R</i>	28
<i>Table 3: Technical specifications, 14.150R</i>	29
<i>Table 4: Tooth positions on the outside ring</i>	30
<i>Table 5: Cutter head setup for limescale deposits</i>	31
<i>Table 6: Cutter head setup for wood and plastic deposits</i>	32
<i>Table 7: Cutter head setup for concrete deposits</i>	33
<i>Table 8: Retrofit kit overview</i>	34
<i>Table 9: Cutting tooth accessories</i>	39
<i>Table 10: Retrofit kit</i>	40
<i>Table 11: Cutter head accessories</i>	40
<i>Table 12: Diamond crown drill bit accessories</i>	41
<i>Table 13 Cage accessories</i>	41
<i>Table 14: Miscellaneous accessories</i>	42

A large, high-quality photograph of a water splash, showing a wave of blue water moving from left to right across the bottom half of the page. The water is clear and bubbly, with many small droplets and air bubbles visible. The background is a light, clean white.

enz® technik ag
Schwerzbachstrasse 10
6074 Giswil, Switzerland
Phone +41 41 676 77 66
info@enz.com
www.enz.com