

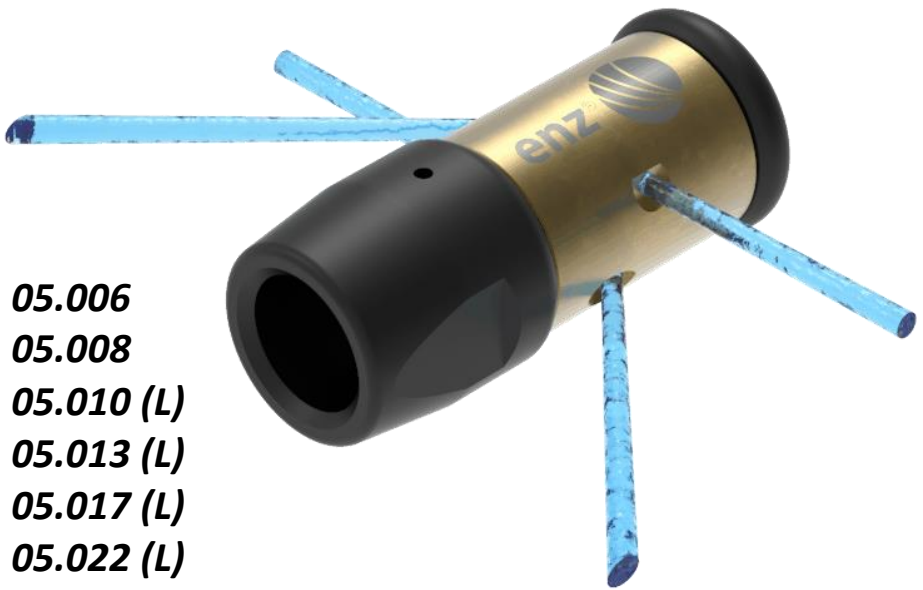

UR Nozzles



- 05.006**
- 05.008**
- 05.010 (L)**
- 05.013 (L)**
- 05.017 (L)**
- 05.022 (L)**
- 05.028 (L)**

Operating Manual
English
September 23 | Version 1.2



Table of Contents

Table of Contents	2
Preface	4
Purpose of the document	4
1 ⚠ Safety	5
1.1 ⚠ Consequences when disregarding the safety instructions	5
1.2 ⚠ Target group	5
1.3 ⚠ Requirements on the user	5
1.4 ⚠ Meaning of the general safety instructions	6
1.5 ⚠ Types of instructions in these operating instructions	6
1.6 ⚠ Intended use.....	7
1.7 ⚠ Safety instructions for modifications	7
1.8 ⚠ Personal protective equipment.....	8
1.9 ⚠ General safety instructions	10
1.10 Applied Standards and Directives.....	11
2 Rights.....	12
2.1 Copyright	12
2.2 Disclaimer	12
2.3 Guarantee conditions	12
3 Environment	13
3.1 Disposal	13
3.2 Environmental protection	13
4 Technical data	14
4.1 Introduction.....	14
4.2 Area of application	14
4.3 Designation of the parts	14
4.4 Legend for technical data	14
4.5 UR6 05.006	15
4.6 UR8 05.008	15
4.7 UR10 short 05.010.....	16
4.8 UR10 long 05.010	17
4.9 UR13 short 05.013.....	18
4.10 UR13 long 05.013	19
4.11 UR17 short 05.017.....	20
4.12 UR17 long 05.017	21
4.13 UR22 short 05.022.....	22
4.14 UR22 long 05.022	22
4.15 UR28 short 05.028.....	23
4.16 UR28 long 05.028	23

5 Installation.....24

5.1 Equipping.....24

5.2 Assembly of the tools24

5.3 Preparation work.....24

5.4 Setting up the workplace.....25

6 Operation.....26

6.1 Operating principle.....26

6.2 Work methods.....27

6.3 Operating the UR nozzle.....27

7 Maintenance.....29

7.1 Changing the nozzle inserts29

7.2 Care31

7.3 Storage31

8 Spare parts / Accessories32

8.1 Nozzle inserts32

8.2 Maintenance32

9 Directory33

9.1 Tables33

9.2 Figures33

10 Notes34

Version	Revision	Date	Signature
1.0	Erstellt	November 20	fkr
1.1	Frontstrahl ergänzt	August 22	bbi
1.2	Durchfluss UR 28 angepasst	September 23	bbi

Preface

Dear valued customer,

Thank you for the confidence and trust you've placed in us by purchasing one of our products.

We always appreciate suggestions and new design ideas. Your feedback will help us improve the design of our product and the associated documentation.

If you have any questions or suggestions, please contact our Customer Service Department.

enz® technik ag

Tel. +41 41 676 77 66

info@enz.com



Feedback form

www.enz.com/en/header/feedback

Person responsible for the documentation:

Bryan Bieri (Tech. Support / QM Manager)

We reserve the right to modify and further enhance our products without prior notice as a result of technological advances. Misprints reserved.

Purpose of the document

These operating instructions serve to use our product in a comprehensive sense according to its intended use, correctly, effectively and safely. The users are informed about the risks, reasonably foreseeable misuse and residual risks.



Important!

Before using the product for the first time, read these original operating instructions, handle accordingly and keep them in a safe place for future reference.

Carefully read through the operating instructions before working with the cleaning tool. Make sure that it has been understood by all persons working with the product.

The operating instructions should be made available to the operating personnel at all times. It must be stored at an easily accessible location. If the operating instructions are lost or have been destroyed, a copy can be requested from your local dealer, direct from the manufacturer or printed out online.

1 Safety

1.1 Consequences when disregarding the safety instructions

Disregarding the safety instructions may lead to accidents with serious personal injury, property or environmental damage.

The manufacturer is not liable for damage that results from disregarding the safety instructions.

1.2 Target group

These operating instructions are intended for all persons that are involved in assembly, commissioning and operation of the pipe cleaning tool.

1.3 Requirements on the user

All persons that are involved in the assembly, commissioning and operation of the tool must ...

- be familiar with the cleaning work environment and have professional knowledge;
- be trained and instructed accordingly for the use of the product;
- have read and understood the operating instructions, in particular the chapter « **Safety**».

If the personnel do not have the necessary knowledge, this must be trained. If necessary, this can be carried out by the manufacturer of the pipe cleaning tool.

Only the maintenance and repair activities described in these operating instructions may be carried out by users who fulfil the requirements specified. All other maintenance and repair work may only be carried out by qualified personnel of the manufacturer.







Observe the instructions in the chapter «**Maintenance**».

1.4 ⚠ Meaning of the general safety instructions

The general safety instructions in this chapter inform you about potential residual risks which, despite correct use of the product, may be permanently present or occur unexpectedly.

To avoid personal injury, property or environmental damage, it is essential that all persons working with the product observe the safety instructions. For these persons, it is therefore mandatory that this chapter is read and understood.

1.5 ⚠ Types of instructions in these operating instructions

	DANGER!
	Designates dangers which, if disregarded, will result in death or severe injuries!
	WARNING!
	Designates dangers which, if disregarded, may result in death , severe injuries and / or invalidity!
	CAUTION!
	Designates dangers which, if disregarded, may result in injuries and significant property, financial or environmental damage!
	Information for the technically correct and efficient use of the product.

1.6 ⚠️ Intended use

Due to the high pressures and temperatures, there is a risk of property damage as well as a risk of injury for the user and other persons. For the correct and intended use of the product, the following points must be observed:

- ⚠️ The product may only be operated using filtered fresh water. Filter size 0.005 mm or 0.001 mm (1 µm) and smaller.
- ⚠️ The product may be used exclusively in pipes or pipe-like channels. In doing so, the profile to be cleaned must be closed and surrounded by material.
- ⚠️ The product is suitable for operation in steel pipes.
- ⚠️ Consult the manufacturer for use in pipes made of other materials.
- ⚠️ The product may only be operated with correct hose connections free of faults.
- ⚠️ During operation including setup and clearing work, the cleaning area (shaft, feed, etc.) must be sufficiently secured.
- ⚠️ During operation, **no** persons may remain in the pipes or at the ends of the pipes.
- ⚠️ The max. pressure specified on the nozzle may **not** be exceeded.
- ⚠️ The dirty water may **not** be directed into streams or rivers.
- ⚠️ Before putting into operation each time, the correct state of the product must be checked.
- ⚠️ Defects must be rectified before putting into operation.
- ⚠️ Only flawless tools may be used. (For nuts, use only matching spanners)
- ⚠️ Secure hose lines in such a way that they cannot be damaged during operation.
- ⚠️ Only accessory parts provided and approved by **enz® technik ag** may be used.

1.7 ⚠️ Safety instructions for modifications

It is forbidden to carry out any conversions or modifications to the pipe cleaning tool. Only parts authorised by the manufacturer be used. The manufacturer is not liable for damage that results in conjunction with conversions to the product made at your own authority.

1.8 ⚠️ Personal protective equipment

Wearing personal protective equipment cannot influence or eliminate dangers. PPE can however reduce or eliminate the negative impacts of dangers to persons. They contribute significantly to avoiding accidents and occupational illnesses.

Breathing protection



Isolation device (breathing apparatus) for remaining in dangerous atmospheres and for rescue operations. Isolation devices for self-rescue (self-contained open-circuit compressed air breathing apparatus and regenerative devices) for remaining in channels and for first supply of persons injured.

Harness



Rescue harness or safety clothing with sewn-in neck eyelet. During the rescue operation, the rescue rope is attached to the neck eyelet. Lifting the injured person is carried out, e.g. By means of a rescue lifting device with automatic load backstop.

Protective clothing



Closed work clothing that protects against water jets, contamination of skin and possible infections.

Protective apron



At pressure ranges higher than 800 bar, a protective apron provides additional protection.

Suitable shoes



The safety shoes should, in particular, offer good support, anti-slip and leak proof as well as protect against water jets. At pressure ranges higher than 800 bar, protective gaiters provide additional protection.

Hand protection



Suitable gloves protect against hand injuries and contact against substances hazardous to health and contaminated water.

Hard hat



The hat protects the persons head against falling objects as well as against knocking against fixed components and objects.

**Face protection**

A suitable face protection protects against water jets and contamination.

**Ear protection**

For noise which can damage hearing, e.g. ear protector capsules with integrated headset can be worn.

**Eye protection**

If there is a danger from splitters, splashing of hazardous substances, etc. eyes must be protected.

**Gas detector**

In event of possible poisonous vapours in work areas, a suitable gas detector may be useful.

**Network-independent lighting**

For example, a splash-proof torch or a lamp fixed to a hard hat must be carried.

**Hose guard**

With pressure ranges higher than 800 bar, a suitable hose guard (e.g. Made of Kevlar) provides additional protection against water jets.

1.9 ⚠️ General safety instructions

Danger! | High-pressure water jets



Defective products or incorrect operation of the product may generate dangers from splash water under pressure. Before operation, ensure the trouble-free state of the product. Powerful water jets may cause severe injuries or even severe limbs. Non-observance of the safety instructions may result in **death** or very serious injuries!

Danger! | Poisonous substances



Channels, pipes and tanks may contain poisonous vapours. Wear the prescribed protective equipment such as gas masks, gas alarms and rescue harnesses. Inhaling poisonous vapours or air contaminated with particles may result in **death** or very serious injuries from the particles penetrating into the lungs!

Danger! | Suspended load



In the working environment, there is a danger from suspended loads such as tools or objects on cranes to be cleaned. Never stand under suspended loads. **Death** or very serious injuries may result from objects falling down.

Danger! | Falling objects



In the area of open shafts, objects may fall into the shaft. When inserting the product, never remain directly under the shaft opening. Secure the shaft access against parts that may fall down. Do not throw any tools or objects into the shaft. Never access shafts that are in danger of collapsing. Persons could be buried. Non-observance of safety instructions may result in **death** or very serious injuries!

Warning! | Corrosive substances



Channels, pipes and tanks may contain unknown, corrosive or other harmful substances. Wear the respective protective clothing. Use the prescribed protective equipment. Chemical burns to skin and eyes as well as infections with pathogens may be the consequence.



Warning! | Risk of falling

In the area where work is carried out using the product, open shafts are to be expected. Open shafts must be indicated. Take care where you step. Persons falling may result in **death** or very serious injuries!



Warning! | Hand injuries

With a modification of the product, there is a risk of hand injuries from entrapment or abrasion. Wear gloves when working. Observe where you hold the product. Carry heavy devices with the assistance of a second person. If disregarded, this may result in crushing, abrasion up to the severing of limbs.



Caution! | Tipped objects

With a modification of the product, there is a risk of hand injuries from sharp edges. Wear gloves when working. Observe where you hold the product. If disregarded, this result in cut injuries to hands or other body parts.



Caution! | Risk of falling

In the area where work is carried out with the product, lines and objects are to be expected on the ground. Take care where you step. Keep the operating area clean and tidy. Falling caused by tripping may result in injury.



Caution! | Hot surfaces

The product may heat strongly during operation. This can result in burns.

1.10 Applied Standards and Directives

- Machinery Directive: 2006/42/EC
- EN1829-1:2018 High-pressure water jet machines - Safety requirements - Part 1: Machines
- EN1829-2:2008 High-pressure water jet machines - Safety requirements - Part 2: Hoses, hose lines and connectors
- EN ISO 4413:2010 Hydraulic fluid power - General rules and safety requirements for systems and their components
- Recommended procedure for the use of high-pressure water jet devices (WJTA-IMAC)
- Recommended procedure for high-pressure water jets (WJA)
- Industrial Cleaning Foundation (Stiftung Industrielle Reinigung)(The Netherlands) – SIR

2 Rights

2.1 Copyright

This manual may not be partially or completely copied, photocopied, reproduced, translated or converted in an electronically of machine-readable form without the prior written consent of **enz® technik ag**.

©2023 enz® technik ag, CH-6074 Giswil.
All rights reserved.

2.2 Disclaimer

The manufacturer is not liable for damage that:

- has resulted in conjunction with modifications to the product carried out at your own authority.
- have resulted from disregarding the safety instructions.

2.3 Guarantee conditions

In line with our terms of sales and delivery, we issue a guarantee. However, the guarantee is omitted:

- When used under conditions stipulated otherwise by us.
- When using replacement or accessory parts that are not original from **enz® technik ag**.
- In event of damage caused by:
 - Incorrect use
 - Non-observance of the operating instructions
 - Unsuitable operating material
 - Routing of the hose or pipelines incorrectly or inappropriately
 - Changes, modifications or conversions to the product at your own authority.

3 Environment

3.1 Disposal

Old devices have valuable recyclable materials that should be recycled. Therefore, please dispose of old devices via enz® technik ag or suitable collecting points.

3.2 Environmental protection

Please observe that surfaces can only be cleaned where the composition is known. Chemicals or other poisonous substances must never be released to the environment. Take care to avoid excessive use of water. In this way, you help to protect natural resources.

4 Technical data

4.1 Introduction

The enz® UR nozzles are designed especially for the internal cleaning of pipes up to 1,500 bar. They are suitable for the removal of the hardest deposits on the pipe walls. The UR nozzles are equipped with two radial jets towards the pipe wall as well as two semi-radial jets that are directed downwards.

Due to the offer of different nozzle diameters, the nozzles cover a wide area of application.

4.2 Area of application

- Polishing of small pipes (inner pipe cleaning)
- Short version suitable for elbows
- Especially suitable for heat exchangers
- Suitable for automatic and manual cleaning

4.3 Designation of the parts

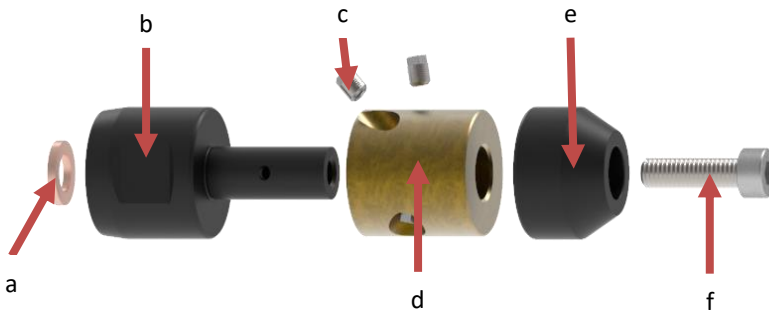

Figure 1: Designation of the parts

4.3.1 Legend

- | | | | |
|---|---------------|---|-------|
| a | Copper disc | d | Rotor |
| b | Stator | e | Cover |
| c | Nozzle insert | f | Screw |

4.4 Legend for technical data

	Connecting thread [“]		Rotating nozzles / bore
	Mass		Area of application
	Maximum operating pressure		Min. flow as max. operating pressure
	Front jet		optional

Table 1: Legend for technical data

4.5 UR6 05.006



Order no.						$\varnothing \times L$					
		mm	mm	mm	inch	mm	inch	l/min	US gpm	bar	psi
05.006-12-M-1	M5 male	4x0.45	-	8-9	0.3-0.4	6x43	0.2x1.7	12	3.2	1,000	14,500

Table 2: Technical data UR6

4.6 UR8 05.008



Order no.						$\varnothing \times L$					
		mm	mm	mm	inch	mm	inch	l/min	US gpm	bar	psi
05.008-14-M-1	M5	4x0.45	-	10-12	0.4-0.5	8x43	0.3x1.7	14	3.7	1,000	14,500
05.008F-16-M-1	M5	4x0.45	0.45	10-12	0.4-0.5	8x43	0.3x1.7	16	4.2	1,000	14,500

Table 3: Technical data UR8

4.7 UR10 short 05.010









Order no.						$\varnothing \times L$				 max	
		mm	mm	mm	inch	mm	inch	l/min	US gpm	bar	psi
05.010-20-M-2	M7	4x0.45	-	12-15	0.5-0.6	10x26	0.4x1.0	20	5.3	1,500	22,000
05.010-20-U-2	1/4" UNF	4x0.45	-	12-15	0.5-0.6	10x26	0.4x1.0	20	5.3	1,500	22,000
05.010-20-N-1	1/16" NPT	4x0.45	-	12-15	0.5-0.6	10x26	0.4x1.0	18	4.8	1,000	14,500
05.010-30-M-2	M7	2x0.55 2x0.50	-	12-15	0.5-0.6	10x26	0.4x1.0	30	7.9	1,500	22,000
05.010-30-U-2	1/4" UNF	2x0.55 2x0.50	-	12-15	0.5-0.6	10x26	0.4x1.0	30	7.9	1,500	22,000
05.010-30-N-1	1/16" NPT	2x0.55 2x0.50	-	12-15	0.5-0.6	10x26	0.4x1.0	25	6.6	1,000	14,500
05.010-40-M-2	M7	2x0.65 2x0.60	-	12-15	0.5-0.6	10x26	0.4x1.0	40	10.6	1,500	22,000
05.010-40-U-2	1/4" UNF	2x0.65 2x0.60	-	12-15	0.5-0.6	10x26	0.4x1.0	40	10.6	1,500	22,000
05.010-40-N-1	1/16" NPT	2x0.65 2x0.60	-	12-15	0.5-0.6	10x26	0.4x1.0	33	8.7	1,000	14,500

Table 4: Technical data UR10 short

4.8 UR10 long 05.010



Order no.						$\varnothing \times L$					
		mm	mm	mm	inch	mm	inch	l/min	US gpm	bar	psi
05.010-20-LM-2	M7	4x0.45	-	12-15	0.5-0.6	10x34	0.4x1.3	20	5.3	1,500	22,000
05.010-20-LU-2	1/4" UNF	4x0.45	-	12-15	0.5-0.6	10x34	0.4x1.3	20	5.3	1,500	22,000
05.010-20-LN-1	1/16" NPT	4x0.45	-	12-15	0.5-0.6	10x34	0.4x1.3	18	4.8	1,000	14,500
05.010-30-LM-2	M7	2x0.55 2x0.50	-	12-15	0.5-0.6	10x34	0.4x1.3	30	7.9	1,500	22,000
05.010-30-LU-2	1/4" UNF	2x0.55 2x0.50	-	12-15	0.5-0.6	10x34	0.4x1.3	30	7.9	1,500	22,000
05.010-30-LN-1	1/16" NPT	2x0.55 2x0.50	-	12-15	0.5-0.6	10x34	0.4x1.3	25	6.6	1,000	14,500
05.010-40-LM-2	M7	2x0.65 2x0.60	-	12-15	0.5-0.6	10x34	0.4x1.3	40	10.6	1,500	22,000
05.010-40-LU-2	1/4" UNF	2x0.65 2x0.60	-	12-15	0.5-0.6	10x34	0.4x1.3	40	10.6	1,500	22,000
05.010-40-LN-1	1/16" NPT	2x0.65 2x0.60	-	12-15	0.5-0.6	10x34	0.4x1.3	33	8.7	1,000	14,500

Table 5: Technical data UR10 Long

4.9 UR13 short 05.013



Order no.						$\varnothing \times L$					
		mm	mm	mm	inch	mm	inch	l/min	US gpm	bar	psi
05.013-20-LM-2	BSPP 1/8"	4x0.45	-	15-20	0.6-0.8	13x30	0.5x1.2	20	5.3	1,500	22,000
05.013-20-LU-2	3/8" UNF	4x0.45	-	15-20	0.6-0.8	13x30	0.5x1.2	20	5.3	1,500	22,000
05.013-20-LN-1	1/8" NPT	4x0.45	-	15-20	0.6-0.8	13x30	0.5x1.2	18	4.8	1,000	14,500
05.013-30-LM-2	BSPP 1/8"	2x0.55 2x0.50	-	15-20	0.6-0.8	13x30	0.5x1.2	30	7.9	1,500	22,000
05.013-30-LU-2	3/8" UNF	2x0.55 2x0.50	-	15-20	0.6-0.8	13x30	0.5x1.2	30	7.9	1,500	22,000
05.013-30-LN-1	1/8" NPT	2x0.55 2x0.50	-	15-20	0.6-0.8	13x30	0.5x1.2	25	6.6	1,000	14,500
05.013-40-LM-2	BSPP 1/8"	2x0.65 2x0.60	-	15-20	0.6-0.8	13x30	0.5x1.2	40	10.6	1,500	22,000
05.013-40-LU-2	3/8" UNF	2x0.65 2x0.60	-	15-20	0.6-0.8	13x30	0.5x1.2	40	10.6	1,500	22,000
05.013-40-LN-1	1/8" NPT	2x0.65 2x0.60	-	15-20	0.6-0.8	13x30	0.5x1.2	33	8.7	1,000	14,500

Table 6: Technical data UR13 short

4.10 UR13 long 05.013









Order no.											
		mm	mm	mm	inch	mm	inch	l/min	US gpm	bar	psi
05.013-20-LM-2	BSPP 1/8"	4x0.45	-	15-20	0.6-0.8	13x40	0.5x1.6	20	5.3	1,500	22,000
05.013-20-LU-2	3/8" UNF	4x0.45	-	15-20	0.6-0.8	13x40	0.5x1.6	20	5.3	1,500	22,000
05.013-20-LN-1	1/8" NPT	4x0.45	-	15-20	0.6-0.8	13x40	0.5x1.6	18	4.8	1,000	14,500
05.013-30-LM-2	BSPP 1/8"	2x0.55 2x0.50	-	15-20	0.6-0.8	13x40	0.5x1.6	30	7.9	1,500	22,000
05.013-30-LU-2	3/8" UNF	2x0.55 2x0.50	-	15-20	0.6-0.8	13x40	0.5x1.6	30	7.9	1,500	22,000
05.013-30-LN-1	1/8" NPT	2x0.55 2x0.50	-	15-20	0.6-0.8	13x40	0.5x1.6	25	6.6	1,000	14,500
05.013-40-LM-2	BSPP 1/8"	2x0.65 2x0.60	-	15-20	0.6-0.8	13x40	0.5x1.6	40	10.6	1,500	22,000
05.013-40-LU-2	3/8" UNF	2x0.65 2x0.60	-	15-20	0.6-0.8	13x40	0.5x1.6	40	10.6	1,500	22,000
05.013-40-LN-1	1/8" NPT	2x0.65 2x0.60	-	15-20	0.6-0.8	13x40	0.5x1.6	33	8.7	1,000	14,500

Table 7: Technical data UR13 long

4.11 UR17 short 05.017









Order no.											
		mm	mm	mm	inch	mm	inch	l/min	US gpm	bar	psi
05.017-30-B-2	BSPP 1/4"	4x0.50	*	19-26	0.7-1.0	17X37	0.7x1.5	30	7.9	1,500	22,000
05.017-30-UC-2	9/16" UNF	4x0.50	*	19-26	0.7-1.0	17X37	0.7x1.5	30	7.9	1,500	22,000
05.017-30-NB-1	1/4" NPT	4x0.50	*	19-26	0.7-1.0	17X37	0.7x1.5	25	6.6	1,000	14,500
05.017-50-B-2	BSPP 1/4"	2x0.70 2x0.65	*	19-26	0.7-1.0	17X37	0.7x1.5	50	13.2	1,500	22,000
05.017-50-UC-2	9/16" UNF	2x0.70 2x0.65	*	19-26	0.7-1.0	17X37	0.7x1.5	50	13.2	1,500	22,000
05.017-50-NB-1	1/4" NPT	2x0.70 2x0.65	*	19-26	0.7-1.0	17X37	0.7x1.5	40	10.6	1,000	14,500

Table 8: Technical data UR17 short

*Front jet optional

4.12 UR17 long 05.017









Order no.											
		mm	mm	mm	inch	mm	inch	l/min	US gpm	bar	psi
05.017-30-B-2	BSPP 1/4"	4x0.50	*	19-26	0.7-1.0	17X51	0.7x2.0	30	7.9	1,500	22,000
05.017-30-UC-2	9/16" UNF	4x0.50	*	19-26	0.7-1.0	17X51	0.7x2.0	30	7.9	1,500	22,000
05.017-30-NB-1	1/4" NPT	4x0.50	*	19-26	0.7-1.0	17X51	0.7x2.0	25	6.6	1,000	14,500
05.017-50-B-2	BSPP 1/4"	2x0.70 2x0.65	*	19-26	0.7-1.0	17X51	0.7x2.0	50	13.2	1,500	22,000
05.017-50-UC-2	9/16" UNF	2x0.70 2x0.65	*	19-26	0.7-1.0	17X51	0.7x2.0	50	13.2	1,500	22,000
05.017-50-NB-1	1/4" NPT	2x0.70 2x0.65	*	19-26	0.7-1.0	17X51	0.7x2.0	40	10.6	1,000	14,500

Table 9: Technical data UR17 long

*Front jet optional

4.13 UR22 short 05.022









Order no.						$\varnothing \times L$					
		mm	mm	mm	inch	mm	inch	l/min	US gpm	bar	psi
05.022-A-2	BSPP 1/4"	4xM4	*	24-33	0.9-1.3	23x48	0.9x1.9	18	4.8	1,500	22,000
05.022-UB-2	9/16" UNF	4xM4	*	24-33	0.9-1.3	23x48	0.9x1.9	18	4.8	1,500	22,000
05.022-NB-1	3/8" NPT	4xM4	*	24-33	0.9-1.3	23x48	0.9x1.9	15	4.0	1,000	14,500

Table 10: Technical data UR22 short

4.14 UR22 long 05.022









Order no.						$\varnothing \times L$					
		mm	mm	mm	inch	mm	inch	l/min	US gpm	bar	psi
05.022-LA-2	BSPP 1/4"	4xM4	*	24-33	0.9-1.3	23x63	0.9x2.5	18	4.8	1,500	22,000
05.022-LUB-2	9/16" UNF	4xM4	*	24-33	0.9-1.3	23x63	0.9x2.5	18	4.8	1,500	22,000
05.022-LNB-1	3/8" NPT	4xM4	*	24-33	0.9-1.3	23x63	0.9x2.5	15	4.0	1,000	14,500

Table 11: Technical data UR22 long

*Front jet optional

4.15 UR28 short 05.028



Order no.											
		mm	mm	mm	inch	mm	inch	l/min	US gpm	bar	psi
05.028-A-2	BSPB 1/4"	4xM4	*	30-42	1.2-1.7	28x57	1.1x2.2	30	7.9	1,500	22,000
05.028-UB-2	9/16" UNF	4xM4	*	30-42	1.2-1.7	28x57	1.1x2.2	30	7.9	1,500	22,000
05.028-NB-1	3/8" NPT	4xM4	*	30-42	1.2-1.7	28x57	1.1x2.2	25	6.6	1,000	14,500

Table 12: Technical data UR28 short

4.16 UR28 long 05.028



Order no.											
		mm	mm	mm	inch	mm	inch	l/min	US gpm	bar	psi
05.028-LA-2	BSPB 1/4"	4xM4	*	30-42	1.2-1.7	28x78	1.1x3.1	30	7.9	1,500	22,000
05.028-LUB-2	9/16" UNF	4xM4	*	30-42	1.2-1.7	28x78	1.1x3.1	30	7.9	1,500	22,000
05.028-LNB-1	3/8" NPT	4xM4	*	30-42	1.2-1.7	28x78	1.1x3.1	25	6.6	1,000	14,500

Table 13: Technical data UR28 long

*Front jet optional

5 Installation

5.1 Equipping

To match the UR nozzle optimally to the pump, enz[®] technik ag needs the following parameters for each order:

- | | | |
|---------------------|---------|--------|
| • Pumping capacity: | l/min | US gpm |
| • Pump pressure: | bar | psi |
| • Hose diameter: | mm | inch |
| • Hose length: | m | feet |
| • Hose material: | Plastic | Rubber |



If changes are made to the parameter, you should re-calibrate the tool.

5.2 Assembly of the tools

The UR nozzle is delivered ready for operation. After unpacking, check, that the delivery is complete. Then the UR nozzle is screwed onto the high-pressure hose or the lance. An additional copper washer is enclosed as seal in the stator for metric and BSPP threads. The different thread dimensions can be viewed in chapter «Technical data» from page [14](#).

As standard, the tool rotates counter-clockwise. This means that it cannot be disconnected from the hose during operation.

5.3 Preparation work

Before use, we recommend clarifying several points. Knowledge of the following points are useful for the preparation and setting of the tool:

- Pipe run
- Internal diameter of the pipe to be processed
- Material quality of the pipe to be processed
- Type of contamination in the pipe
- Access possibilities to the pipe

5.4 Setting up the workplace

Before starting work, the following measures must be taken:

- ⚠ Install any barriers and protective equipment (Triopan warning sign, fencing ropes, etc.).
- ⚠ Obtain the necessary information about the waste water introduced to the pipe (chemical substances, gases, vapours, etc.).
- ⚠ The necessary measuring devices such as explosimeter, oxygen meter, gas alarm, etc. must be ready for use.
- ⚠ The working area must be cordoned off such that there is no danger for other persons.
- ⚠ Make sure that the suitable nozzles are present for the pipe cleaning. The area of application of each nozzle is apparent in chapter “Technical data”, from page **14**.
- ⚠ The pipe run (plans) must be known before starting work in order to prevent the nozzle from exiting at the end of the line. Possible exit location must be monitored by support staff.
- ⚠ The surface of the workplace must be clean and have sufficient grip, loose obstructions at the workplace must be removed.
- ⚠ Ensure that the workplace is sufficiently illuminated.
- ⚠ The workplace must be dimensioned such that the high-pressure blaster has sufficient freedom of movement and can assume a stable working posture.
- ⚠ The workplace must ensure that water can drain or run away.
- ⚠ Scaffolding must be fixed, stable and secured against tipping, moving and falling over.
- ⚠ Work platforms must be setup in a stable manner and must not be moved by the cleaning work.
- ⚠ Scaffolding and work platforms must comply with the standards on occupational protection and may only be installed by trained specialist personnel.
- ⚠ Before starting work, the high-pressure machine operator and high-pressure blaster must agreed clearly defined hand signals for switching the high-pressure system on and off as under certain circumstances, acoustic communication may not function due to the noise level.
- ⚠ Loose parts to be cleaned must be secured before commencing work.

6 Operation

6.1 Operating principle

The rotor (1) is suspended on the stator (2) by a thin film of water. The UR nozzles have four jets on the rotor (1). The two radial drive jets (3) drive the UR nozzle, loosen the deposits on the pipe wall and polish this at the same time. Two semi-radial brake jets (4) ensure for a continuous rotation, pull the nozzle forwards and rinse away the material removed.

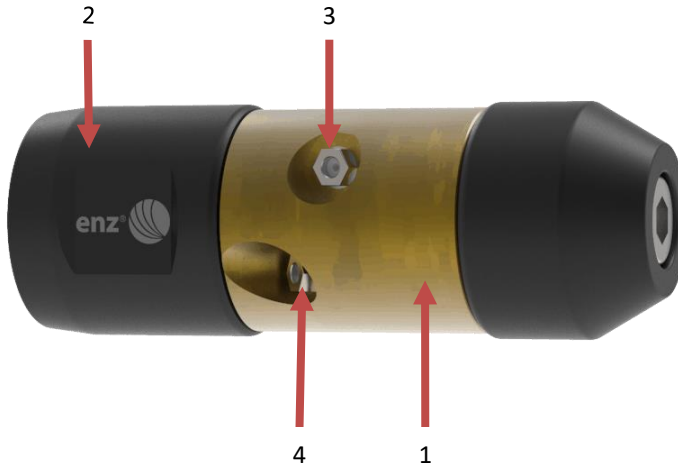

Figure 2: Operating principle of the UR nozzles

6.2 Work methods

Generally, the safest method should be selected. The following belong to the different methods:

- fully automated cleaning
- semi-automatic cleaning
- manual cleaning when using a spiral with stop ring and hose catcher

6.3 Operating the UR nozzle

1. Flush the entire system.
2. Measure the length of the pipe to be cleaned (marking on the shaft) and check this during cleaning.
3. Screw the UR nozzle onto the high-pressure hose.
4. Push the entire length of the tool into the pipe to be cleaned.
5. Increase the pressure to the work pressure.
6. Start cleaning the pipe.
7. When pulling the nozzle back, continue running the water. This prevent dirty water running into the inside of the UR nozzle through the openings.

Operation of the UR nozzles is possible only when using a hose retention system. This prevents the UR nozzle from exiting the pipe during operation.



DANGER!

UR nozzles must never be operated outside of pipes. This may result in death or very serious injuries.



DANGER!

The maximum work pressure must never be exceeded; there is potential mortal danger (see “Technical data” from page **14**).

If the nozzle ruptures, walls of the pipe may be pierced through and parts thrown away at high speed.



DANGER!

Operation of high-pressure water jet systems directly under or in the vicinity of high-voltage plants is forbidden. This may result in death or very serious injuries.

DANGER!

When working in closed rooms, poisonous vapours may accumulate. Wear the prescribed protective equipment such as gas masks, gas alarms. Inhaling poisonous vapours or air contaminated with particles may result in **death** or very serious injuries from the particles penetrating into the lungs!

WARNING!

When working with high-pressure water jets, an emergency escape person who maintains permanent visual contact with the high-pressure cleaner during the cleaning is absolutely essential.

CAUTION!

Work only with filtered water (filter size 0.005 mm or 0.001 mm (1 µm) and smaller). This may result in over pressure caused by blockages.



To increase safety during work, we recommend using a hose breakage protection.



With strongly contaminated pipes we recommend that, the tool is pulled back at regular distances. This prevents clogging from fragments and detached material.



When cleaning with hot water (max. 100°C) or additives, it must be observed that the entire system must be suitable for this.



After use, blast through the tools with compressed air and dry them up. Then preserve the tool with Motorex Oil Spray Bio (C191).

7 Maintenance

The maintenance and repair activities described in these operating instructions may only be carried out by users who have the necessary knowledge.

7.1 Changing the nozzle inserts

After being used each time, the nozzle inserts must be checked visually for damage in order to guarantee an optimum cleaning performance. The wear depends on the degree of contamination of the water used.



CAUTION!

Worn nozzle inserts impair the cleaning performance and there is an increased risk when working with higher pressures. This can result in damage to the tool.

Another reason to change nozzle inserts is a repositioning. In this case, the JetCalc must be used for determination of the nozzle inserts.

Follow the next steps in order to replace the nozzle inserts:

1. Clean the nozzle insert. During the approx. 10 seconds, heat it with the gas torch (C158).
2. Disassemble the nozzle insert using the socket spanner WAF3.5 (C104 or C261).
3. Clean the threaded hole and the new nozzle insert, e.g. with acetone.



- 4. Coat the thread of the nozzle insert with Loctite 638 (C109).

- 5. Assembling the nozzle insert using the socket spanner WAF3.5 (C104 or C261).

- 6. Leave the adhesive to harden for at least 48 hours at room temperature (approx. 22°C).



Table 14: Changing the nozzle inserts



CAUTION!

The nozzle inserts must be replaced by identical nozzle inserts. This can result in the speed and kick-back force changing.



CAUTION!

Never use a pipe wrench or pliers with teeth. These may damage the tool or the hose. This may lead to the tool bursting during operation.



The nozzle inserts and the female thread on the tool must be clean, dry and free from oil and grease.

7.2 Care

The UR nozzles must be thoroughly cleaned after being used each time. After cleaning, the UR nozzles must be lubricated with Motorex Oil Spray Bio (C191) to protect them against corrosion.

7.3 Storage

The UR nozzles must be stored in a dry location protected from dust. We recommend using a plastic container with lid.

8 Spare parts / Accessories

8.1 Nozzle inserts

Figure	Designation	Article number
	Nozzle insert M4	22.04

Table 15: Nozzle inserts

8.2 Maintenance





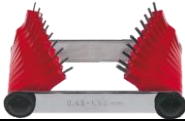

Figure	Designation	Article number
	Wiha socket wrench 3.5 mm	C104
	Futuro socket wrench 3.5 mm	C261
	Gas burner	C158
	Oil Spray Bio	C191
	Loctite 638 50 ml	C109
	Nozzle gauge with 20 pins 0.45-1.50 mm	C200
	Nozzle cleaning set	C202

Table 16: Maintenance accessories

9 Directory

9.1 Tables

<i>Table 1: Legend for technical data</i>	14
<i>Table 2: Technical data UR6</i>	15
<i>Table 3: Technical data UR8</i>	15
<i>Table 4: Technical data UR10 short</i>	16
<i>Table 5: Technical data UR10 Long</i>	17
<i>Table 6: Technical data UR13 short</i>	18
<i>Table 7: Technical data UR13 long</i>	19
<i>Table 8: Technical data UR17 short</i>	20
<i>Table 9: Technical data UR17 long</i>	21
<i>Table 10: Technical data UR22 short</i>	22
<i>Table 11: Technical data UR22 long</i>	22
<i>Table 12: Technical data UR28 short</i>	23
<i>Table 13: Technical data UR28 long</i>	23
<i>Table 14: Changing the nozzle inserts</i>	30
<i>Table 15: Nozzle inserts</i>	32
<i>Table 16: Maintenance accessories</i>	32

9.2 Figures

<i>Figure 1: Designation of the parts</i>	14
<i>Figure 2: Operating principle of the UR nozzles</i>	26

10 Notes

A dynamic splash of clear blue water with numerous bubbles, set against a light blue background, occupies the lower half of the page.

enz® technik ag
Schwerzbachstrasse 10
CH-6074 Giswil / Switzerland
Tel. +41 41 676 77 66
info@enz.com
www.enz.com