



# Wire Rope and Chain Scrapers

## 10.028



**Operating Manual**  
**English**  
**August 24 | Version 1.1**



# Table of Contents

<b>Preface</b> .....	<b>4</b>
<b>Purpose of the document</b> .....	<b>4</b>
<b>1 Safety</b> .....	<b>5</b>
1.1 Noncompliance with the safety information and its consequences .....	5
1.2 Target group .....	5
1.3 User requirements .....	5
1.4 Explanation of general safety instructions .....	6
1.5 Information provided in these operating instructions .....	6
1.6 Intended use.....	6
1.7 Safety warnings for modifications .....	7
1.8 Protective equipment for working in manholes, excavations, and sewer lines .....	7
1.9 General safety instructions .....	9
<b>2 Legal</b> .....	<b>11</b>
2.1 Copyright .....	11
2.2 Exclusion of liability .....	11
2.3 Warranty conditions.....	11
<b>3 Wire rope and chain scrapers</b> .....	<b>12</b>
3.1 Introduction.....	12
3.2 Application .....	12
<b>4 Installation</b> .....	<b>13</b>
4.1 Assembling the tools .....	13
4.2 Preparatory work .....	13
4.3 Setting up the work area .....	13
4.4 Adjusting the wire rope and chain scraper to the sewer line diameter .....	14
<b>5 Operation</b> .....	<b>16</b>
5.1 How to operate the tools .....	16
5.2 Cleaning pipes with minor damage .....	16
5.3 After use .....	17
5.4 Completing the work process.....	17
5.5 Troubleshooting .....	17
5.5.1 Chain scraper is prevented from rotating .....	17
5.5.2 No more forward movement .....	17
<b>6 Maintenance</b> .....	<b>19</b>
6.1 Maintenance after each use.....	19
6.2 Nozzle inserts .....	19
6.2.1 Replacing the nozzle inserts.....	19
6.3 Replacing parts .....	20

# Operating Manual

6.4	Disposal, environmental protection .....	20
<b>7</b>	<b>Technical data .....</b>	<b>21</b>
7.1	Chain settings .....	23
7.2	Cage adjustments .....	24
7.3	Converting a chain scraper to milling cutter without impact .....	24
7.4	Converting the milling cutter without impact to chain scraper .....	25
7.5	Scope of delivery .....	26
<b>8</b>	<b>Index.....</b>	<b>27</b>
8.1	Figure.....	27
8.2	Drawing .....	27

Version	Revision	Date	Initials
1.0	Created	August 22	bbi
1.1	Exchanged the article number of the Threaded pin	August 24	bbi

## Preface

**Dear valued customer,**

Thank you for the confidence and trust you've placed in us by purchasing one of our products.

We always appreciate suggestions and new design ideas. Your feedback will help us improve the design of our product and the associated documentation.

If you have any questions or suggestions, please contact our Customer Service Department.

**enz® technik ag**

Tel. +41 41 676 77 66

info@enz.com



**Feedback form**

[www.enz.com/en/header/feedback](http://www.enz.com/en/header/feedback)

Person responsible for documentation:

Bryan Bieri (Tech. Support / QM Manager)

We reserve the right to modify and further enhance our products without prior notice as a result of technological advances. Misprints reserved.

## Purpose of the document

The purpose of this manual is to instruct you on how to use our product correctly, effectively, safely, and for its intended purpose. The user will be informed about risks, reasonably foreseeable misuse, and residual risks.



---

### **Important!**

Read carefully before use.

Keep for later reference.

---

Please read this operating manual thoroughly before using the cleaning tool. Make sure that all employees who work with the product know how to use it correctly.

The operating manual must be available to all operating personnel at all times. It must be kept in an easily accessible place.

If the manual is misplaced or destroyed, a new copy can be requested from your nearest dealer or from the manufacturer directly.

# 1 Safety

## 1.1 Noncompliance with the safety information and its consequences

Disregarding these safety instructions may lead to accidents and severe personal injuries, material damage, and damage to the environment.

The manufacturer cannot be held responsible for any damages resulting from non-compliance with these instructions.

## 1.2 Target group

This manual is intended for all persons who will be involved in the assembly, start-up, and operation of the pipe cleaning tool.

## 1.3 User requirements

Personnel intending to assemble, start up and operate the tool must...

- Be familiar with the field of sewer maintenance work and possess the appropriate technical knowledge.
- Be trained and instructed appropriately in the use of the product.  
Have read and understood the operating manual, in particular the section on **"Safety."**

If your personnel do not possess the necessary knowledge, they must be trained and instructed on it. If necessary, the pipe cleaning tool manufacturer can provide this instruction and training.

Only the maintenance and service activities described in this manual may be performed by users who have met the above-listed requirements. Any additional maintenance and service work may be performed only by qualified specialist personnel from the manufacturer.



Please refer to the section on **"Maintenance"**.

---

## 1.4 Explanation of general safety instructions

The general safety instructions in this section provide information about potential residual risks, which are inherent to the product and may occur unexpectedly, despite the proper usage of the product.

In order to prevent personal injuries, material damage, and damage to the environment, all personnel working with this product must comply with these safety instructions. It is mandatory for said personnel to read and to understand the information provided in this section.

## 1.5 Information provided in these operating instructions



### DANGER!

Noncompliance may lead to serious injury or **loss of life**.



### WARNING!

Noncompliance may lead to serious injury and / or cause a long-term disability.



### CAUTION!

Noncompliance may lead to injury and considerable material damage, financial loss or damage to the environment.



Information on the technically correct and efficient use of the product.

## 1.6 Intended use

The product is designed to clean the insides of pipes (sewer pipes). The following points must be followed to ensure proper use of the product:

- ⚠ The cleaning tool may be used only in pipes or pipe-like sewers. The profile to be cleaned must be free of leaks and surrounded by material.
- ⚠ The tool may be used on the following types of pipes:
  - PE pipes
  - Steel pipes
  - Concrete pipes
- ⚠ For use in pipes made of other material, please consult the manufacturer.

- ⚠ The product may be operated only in pipes with correctly installed and defect-free connections.
- ⚠ Cleaning areas (manholes, pipe branches etc.) need to be sufficiently secured during the operation, including during construction and cleaning work.
- ⚠ During the cleaning operation, **no** personnel are allowed inside the pipes or at either end of the pipes.
- ⚠ The maximum pressure indicated on the nozzle may **not** be exceeded.
- ⚠ Wastewater may **not** be drained into watercourses (creeks, rivers etc.).
- ⚠ The product must be inspected to ensure it is in proper working order before every start-up.
- ⚠ Defects must be rectified before start-up.
- ⚠ Use the tool only as intended. (Use only the correct wrench for nuts).
- ⚠ Secure the hose lines in such a way that they cannot become damaged during operation.
- ⚠ Only the accessories provided and approved by **enz® technik ag** may be used.

## 1.7 Safety warnings for modifications

No other changes or modifications to the pipe cleaning tool may be performed. Only parts authorized by the manufacturer may be used. The manufacturer is not liable for damage resulting from unauthorized changes to the product.

## 1.8 Protective equipment for working in manholes, excavations, and sewer lines

The employer must provide suitable personal protective equipment and ensure that it is worn by the employees during work.

In the following section, the protective equipment prescribed by Schweizerische Unfallversicherung SUVA (the Swiss Accident Insurance Organization) will be described.

For more information on this, refer to the brochure:

**Safe entry and working in manholes, excavations, and sewer lines  
(in German, French & Italian)**

**Order number: 44062.d**

Suva  
Schweizerische Unfallversicherungsanstalt  
Arbeitsicherheit  
Postfach, 6002 Lucerne, Switzerland  
For information:  
Phone +41 41 419 51 11  
For orders:  
[www.suva.ch/waswo](http://www.suva.ch/waswo)  
Phone +41 41 419 58 51



**Respirators**

Self-contained respiratory equipment for spending time in dangerous atmospheres and for use during rescue operations.



**Respirators**

Self-rescue respiratory equipment (devices with compressed air tanks or regeneration devices) for working in sewers and for first aid for injured persons.



**Rescue harness**

Rescue harness or protective clothing with a loop sewn into the neck. During rescue, the rescue rope will be attached to the neck loop. Injured persons will be lifted out using a rescue lifting device with a self-actuating load brake.



**Suitable working clothing**

Leak-proof clothing protects the skin from becoming soiled and from possible infections. Visually conspicuous work clothing makes the employee more visible to traffic.



**Appropriate footwear**

Safety footwear should, in particular, have good grip and be slip-resistant and leak-proof (e.g. rubber boots).



**Gloves**

Appropriate gloves will protect you from hand injuries and contact with materials that could impair your health and from untreated water.



**Hardhat**

The hardhat will protect your head from falling objects and from bumping into fixed components and objects.



**Hearing protection**

If there is noise that could damage your hearing, you can wear, e.g. earmuffs with built-in headphones and microphone.



**Eye protection**

Your eyes should be protected against grit, sprayed dangerous substances, etc.



**Lighting independent of the power grid**

For example, you should carry a waterproof flashlight or wear a flashlight attached to your hardhat.

**1.9 General safety instructions**



**Danger! | High-pressure water jets**

Defects in or unintended use of the product could cause hazards due to pressurized water spray. Never remain in the channel during operation. Ensure that the product is in perfect condition before operation. Highly concentrated water jets can cause serious injury and could even sever limbs.



**Danger! | Toxic vapors**

There can be toxic vapors in sewer lines. Wear the prescribed protective equipment such as gas masks, gas warning devices and rescue harnesses. Inhaling toxic vapors or air that is contaminated with particles could be **fatal** or lead to serious injuries if the particles enter the lungs.



**Warning! | Falling objects**

Around open manholes, objects can fall down into the manhole and onto the people below. Never remain directly beneath the manhole opening when guiding the products in. Secure the manhole entrance against parts that could fall. Do not throw any tools or objects down into the manhole. Do not enter any manhole where there is a danger of falling. Personnel could become trapped.



**Warning! | Chemical burns**

There may be unidentified, corrosive, or otherwise harmful substances in the sewer line. Put on appropriate protective clothing. Use the protective equipment prescribed. Otherwise, you could suffer from chemical burns to your skin and eyes or become infected with pathogens.

**Warning! | Falls from height**

Open manholes are to be expected in the area where you will be working with the product. You must warn people about open manholes. Pay attention to where you are walking.

**Warning! | Hand injuries**

In case of tampering with the product, there is a risk of hand injury due to getting caught or abrasion. Wear gloves during work. Pay attention to where you grip the product. Always have two people carry heavy equipment. Consequences can include crushing injuries, abrasions or even the loss of a limb.

**Caution! | Sharp objects**

If the product is tampered with, there is a risk of hand injuries due to sharp edges. Wear gloves during work. Pay attention to where you grip the product. Consequences can include cutting injuries to your hands or other parts of your body.

**Caution! | Trip hazards**

Lines and other objects are to be expected on the ground in the area around where the product is being used. Pay attention to where you are walking. Keep the area of use tidy. Tripping and falling could cause serious injuries.

## 2 Legal

### 2.1 Copyright

This manual shall not be duplicated partially or in its entirety without the prior written permission of **enz® technik ag**. It shall not be photocopied, reproduced, translated, or converted into an electronic or machine-readable format.

©2024 enz® technik ag, 6074 Giswil, Switzerland.  
All rights reserved

### 2.2 Exclusion of liability

The manufacturer is not liable for damage that:

- Is caused as a result of unauthorized changes to the product.
- Is caused by not following the safety instructions.

### 2.3 Warranty conditions

In accordance with our sales and delivery conditions, we offer a warranty. However, the warranty is voided if:

- The product is used under conditions that are not permitted by us.
- Replacement and accessory parts that are not original replacement and accessory parts from **enz® technik ag** are used.
- If there is damage due to:
  - Improper use
  - Not following the operating manual
  - Unsuitable operating equipment
  - Incorrect or improper routing of the hose or pipelines
  - Unauthorized changes or modifications to or conversions of the product.

## 3 Wire rope and chain scrapers

### 3.1 Introduction

enz® chain scrapers are universally usable tools.

The same tool can be adapted and used for a wide range of pipe diameters. Different deposits such as limescale, cement slurry, roots, etc. can be removed efficiently.

Tools with Art No. 10.XXXR can be operated with recycled water.

In addition, enz® chain scrapers can be modified in various ways. Simple handling and maintenance are also traits that go hand-in-hand with enz® chain scrapers.

### 3.2 Application

- Used to prepare for restoration work, such as relining, grouting, or applying coatings
- Complete root removal
- Removal of incrustations and deposits
- Removal of concrete residues in newly-laid channel pipelines (for acceptance inspection)

## 4 Installation

### 4.1 Assembling the tools

All tools are supplied ready to be used. Once the tools have been unpacked, please check the content for completeness.





### 4.2 Preparatory work



It makes sense to clarify some points before use. Knowledge of the following points is helpful during preparations and when adjusting the wire rope and chain scraper:

- Layout of the pipes
- Inner pipe diameter of the sewer line where work will be performed
- Pipe material of the sewer line where work will be performed
- Type of foreign material in the pipe
- Planned flushing direction → We recommend that you work against the direction of the water flow.
- Any type of gradient in the sewer line where work will be performed
- Access points to the sewer line

### 4.3 Setting up the work area

Prior to working with a wire rope or chain scraper, the following procedures must be followed:

-  Set up barriers and safety equipment (warning triangle, block off the area, etc.)
-  The work area must be blocked off and secured so that there is no risk of falling or other traffic-related dangers.
-  The necessary information on the wastewater flowing through the manhole must be obtained (chemicals, gas, vapors, etc.)
-  Measuring instruments such as explosive gas meters, oxygen meters, gas warning devices, etc. must be readily available.
-  You must ensure that the appropriate nozzle sizes for cleaning the pipes are available. The application range of each nozzle is listed in the "Technical data" section on Page 21.

-  The layout of the pipes (manhole drawings) must be known before starting the work so that the nozzle can be prevented from emerging at a pipe end. Support personnel must be on hand to monitor possible emerging points.
-  Have the liability waiver signed by the customer to protect against any claims for damages.



*Figure 1 Blocked off & signed work area*

#### **4.4 Adjusting the wire rope and chain scraper to the sewer line diameter**

A wire rope or chain scraper must always be adjusted to the inner diameter of the pipe where work will be performed.

Chain lengths are selected to ensure that the ends are always scraping against the pipe wall. This prevents the tool from rotating too fast during operation and causing unnecessary damage to the tool and the pipe.

The only exception is if the work is to be performed in an ovoid profile.

The skids can be adjusted on some articles in the wire rope and chain scraper series; in others, the skids and the chains are replaced based on the sewer line diameter. When adjusting the skid and cage settings, always use the largest possible setting for the inner sewer line diameter being worked on.

To correctly install your wire rope or chain scraper, please refer «Technical data on page 23».

You will find tool-specific information on the chains, ropes and skids to be used and how to adjust them there.

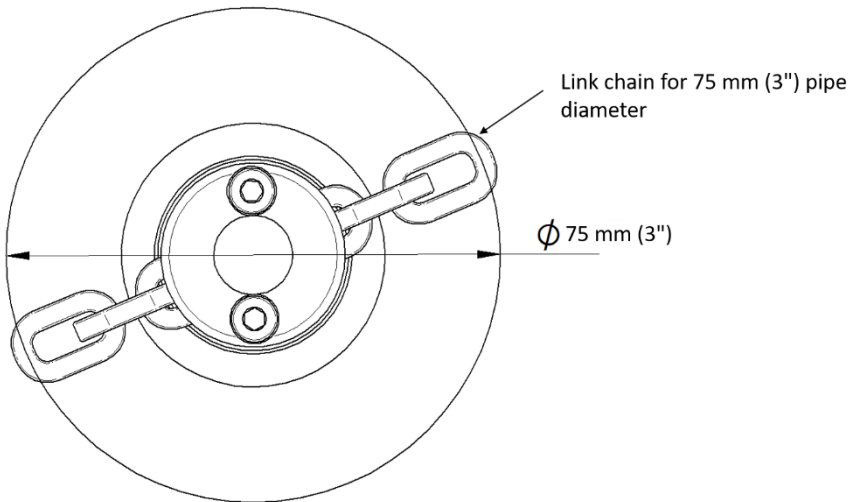

*Drawing 1 Chain length greater than pipe Ø*



**Caution!**

Always use the correct chain or rope length. The chains or ropes must drag along the pipe wall, and they must **not** strike the wall! Otherwise, the pipe wall or the product could become damaged.

## 5 Operation

### 5.1 How to operate the tools

1. Flush all loose debris from the pipe prior to working with a standard nozzle. Loose debris can interfere with the work. If need be, you must use a pointed nozzle or a Bulldog, with their specialized front jet features, to clear the pipe of roots.
2. The chain scraper is screwed onto the hose unrolled from the vehicle. The thread dimension depends on the size of the chain scraper.
3. Push the wire rope or chain scraper at least half of its length into the pipe to be cleaned. If possible, you should work against the direction of flow.
4. Increase the pressure on the wire rope or chain scraper up to 100 – 120 bar (1450 – 1740 psi) - while paying attention to any loss of pressure in the hose.
5. Keep an eye on the forward motion while unrolling the hose and pay attention to the noise from the work. If you notice any irregularities, refer to Troubleshooting in Section 5.5 on Page 17.
6. Also allow water to run when retracting the wire rope and chain scraper so that the nozzles do not become clogged.
7. Close the manhole cover once work is completed.

Normally, the head of the nozzle will turn in a counter-clockwise direction when in use. Meanwhile, the connecting thread will turn in a clockwise direction. This prevents the nozzle from detaching itself from the connecting thread during operation.



Continue to run the water at low pressure when retracting the tool. This prevents wastewater from entering the interior of the nozzle, which can lead to failure.

---

### 5.2 Cleaning pipes with minor damage

Slightly damaged pipes usually exhibit cracks in the pipe wall. If detected, always contact the customer or the appropriate authorities.

When working inside a slightly damaged pipe, extreme caution must be used. Use of the tool is always at your own risk! **enz® technik ag** waives all liability!

**DANGER!**

When cracks are washed out, pipe fragments can break off and the material surrounding the pipe may be flushed out. When in doubt, you should not use the product. Using it in these circumstances can result in collapsed channels.

### 5.3 After use

After you have completed work, you must still do the following:

1. Rinse the tool with fresh water.
2. Spray OIL SPRAY BIO (Item no. C191) on the entire tool. Then manually turn the rotor several times.
3. Then check the tool for traces of wear and replace any defective parts if needed.

### 5.4 Completing the work process

If possible, use a camera to inspect the cleaned pipes. Look out in particular for any damage and ensure that no liquids can escape into the environment. All manholes must be closed after the cleaning has been completed.

### 5.5 Troubleshooting

#### 5.5.1 Chain scraper is prevented from rotating

The wire rope or chain scraper makes a characteristic noise. This sound will tell you whether the chain scraper is working or has become “stuck”.

When the chain scraper no longer turns:

1. Reduce the pressure.
2. Pull the chain scraper back about 500 mm (20 inch)
3. Carefully increase the pressure until you can hear that the chain scraper is working again.

#### 5.5.2 No more forward movement

There are two possible reasons why the wire rope or chain scraper is no longer moving forward:

- A gap or relative displacement between two pipes is too large. There is a danger that the guide roller is stuck.
- The wire rope or the chain has caught on something or has become wedged in a gap.

If this is the case:

1. Pull the tool back.
2. Try to work from the other side.

If there is a danger that the pin bolt chains have become caught in existing or previously flushed-out gaps, then link chains should be used. If the gap is more than 20 mm (0.75 inch), then the chain scraper is not suitable.

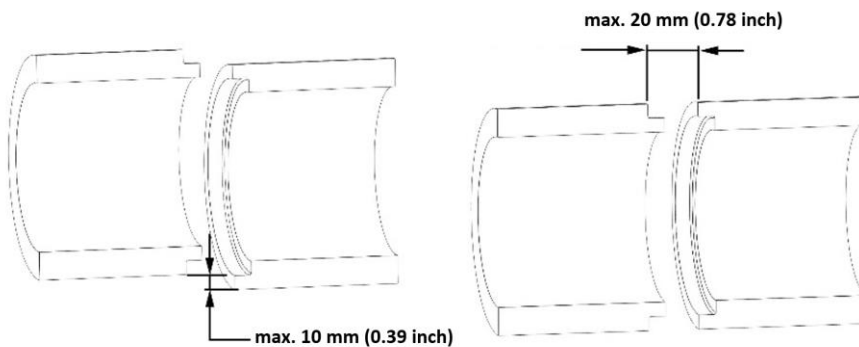

*Drawing 2 Maximum offset*

## 6 Maintenance

The maintenance and service activities described in this manual may be performed only by users who have the required knowledge.

### 6.1 Maintenance after each use

1. Check the inserts for clogging.
2. Then check the tool for traces of wear and replace any defective parts if needed.
3. For corrosion protection and care, treat the tool with OIL SPRAY BIO (Item No. C191).

### 6.2 Nozzle inserts

The nozzle inserts must be inspected regularly. Nozzle wear and tear depends on the degree of contamination in the water used. If recycled water is being used, the nozzle inserts must be inspected **daily** and cleaned if necessary.



#### CAUTION

Worn nozzle inserts impair cleaning results and increase risk when working with high pressure. If recycled water is being used, the nozzle inserts must be inspected daily.

If you do not know the nozzle diameter, JetCalc must be used to determine it.

#### 6.2.1 Replacing the nozzle inserts

1. Remove the defective nozzle inserts.
2. Clean the threaded holes and the new inserts. All threads should be grease-free.
3. Coat the nozzle insert threads with Loctite No.243 adhesive (Art. No.C192).
4. Immediately screw the nozzle inserts into the tool body as far as they will go, then use a socket wrench to slightly tighten each insert.
5. Wait at least 24 hours until the adhesive has hardened.

**CAUTION!**

Damaged nozzle inserts may be replaced only with identical nozzle inserts of the same diameter. If the tool is not correctly assembled, the tool or the pipe may become damaged.

If the tool is due to remain unused for an extended period, spray the nozzle holes and the connecting threads with OIL SPRAY BIO (Item No. C191).

### 6.3 Replacing parts

A qualified user is allowed to replace all parts that are fitted during installation and the following additional parts:

- Chain sets
- Wire brushes
- Wire rope loops
- Nozzle inserts
- Skids & cages



*Figure 2 Oil Spray Bio, 500 ml*

Any additional maintenance and service work may be performed only by qualified specialist personnel from the manufacturer.

### 6.4 Disposal, environmental protection

The tools do not require any special disposal procedure, and they can be disposed of with other scrap metal without problems.

Please note that pipes are cleaned only if the composition of the wastewater is known (industrial wastewater in particular). Under no circumstances may chemicals or other toxic substances flow through defective pipes and enter the environment.









Defective pipes or leaking substances must be reported to the supervisory body or appropriate authority.

Do not use excessive amounts of water. This will help conserve our natural resources.

## 7 Technical data



Figure 3 10.028

	Connecting thread	<b>1/4" BSPP / 1/4" NPT</b>
	Rotating nozzles/Holes	<b>3 x M4</b>
	Thrust jet	<b>3 x M4</b>
	Recycling	<b>No</b>
	Weight	<b>0.9 kg 1.98 lb</b>
	Application range	<b>40 – 100 mm 2 – 4 inch</b>
	Measures	<b>28 x 81 mm 1.1 x 3.2 inch</b>
	min. flow at 100 bar	<b>20 l/min 5.3 US GPM</b>
	Max. working pressure	<b>350 bar 5000 psi</b>

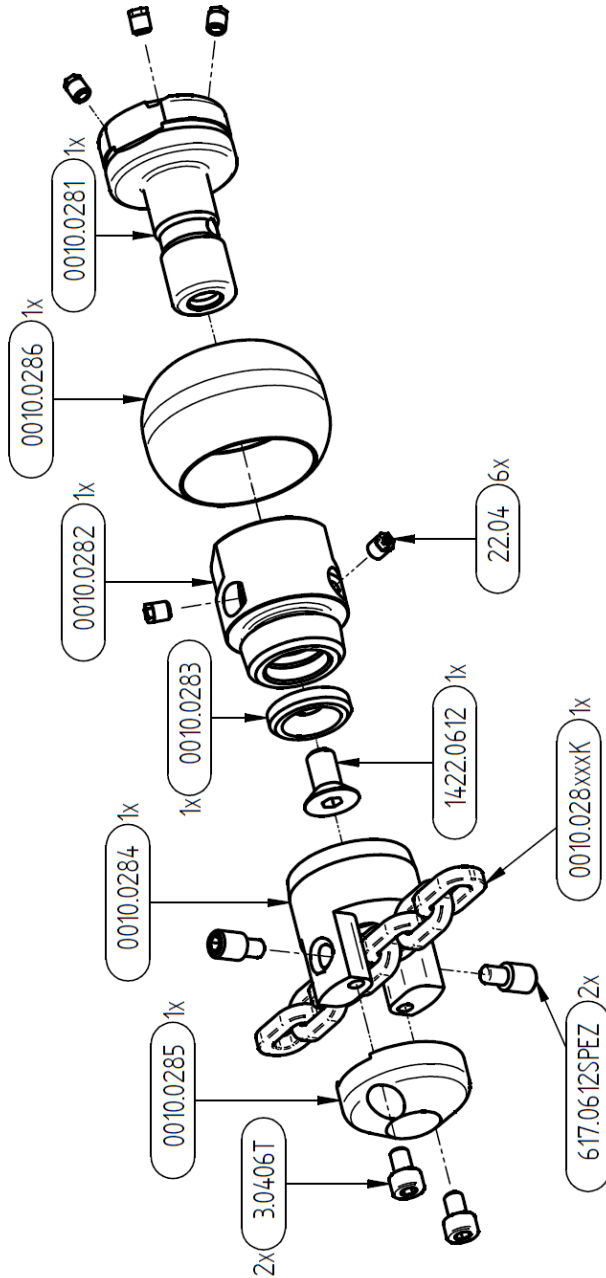

*Drawing 3 Explosion 10.028*

## 7.1 Chain settings

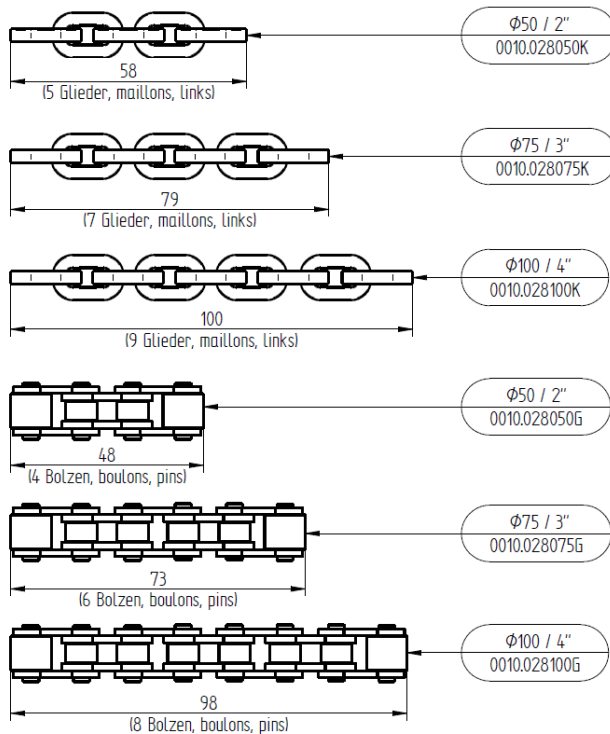

*Drawing 4 All chains for 10.028*

### Replacing the chain:

1. Determine the correct chain length using Drawing 4.
2. Loosen screw 617.0612SPEZ and remove the old chain.
3. Clean the threaded hole.
4. Place the new chain and tighten the screw.

## 7.2 Cage adjustments

The cage cannot be adjusted on the 10.028.

## 7.3 Converting a chain scraper to milling cutter without impact

Using the accessory parts supplied, the chain scraper 10.028 can be converted to a milling cutter without impact. Follow the following steps:

1. Undo the two cylinder head screws (Art. no. 3.0406T) and then remove the cover (Art. no. 0010.0285).
2. Unscrew both threaded pins (Art. no. 617.0612SPEZ) and remove the links or pin bolt chains.
3. Press the nozzle body out of the plastic guide (Art. no. 0010.0286). For this purpose, heat the plastic guide under hot water.
4. Assemble the cutter head (Art. no. 0010.0285M)

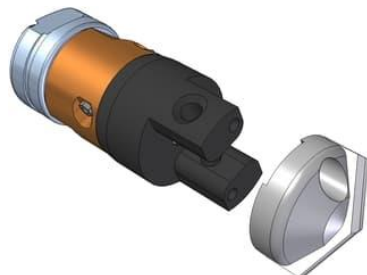
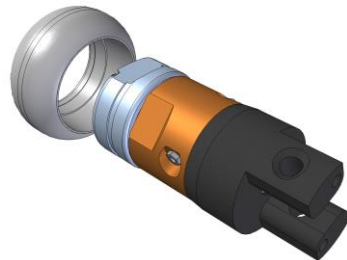
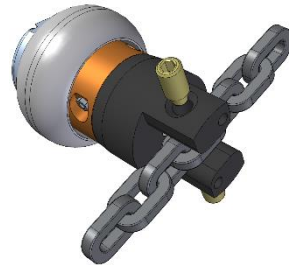
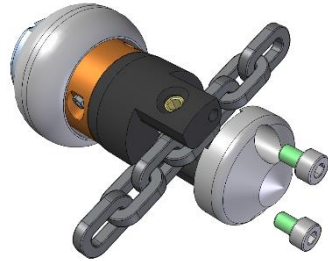

5. Coat both cylinder head screws (Art. no. 3.0406T) with Loctite 243 and screw these into the cutter head (Art. no. 0010.0285M).

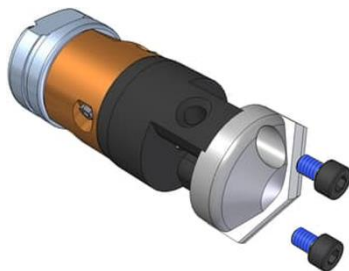
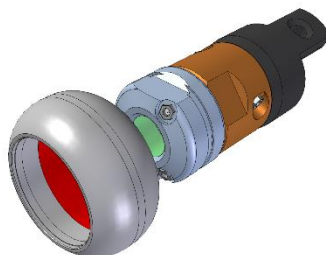

*Figure 4 Converting to milling cutter*

## 7.4 Converting the milling cutter without impact to chain scraper

Reassembly occurs in the reverse sequence.

During assembly of the plastic guide (Art. no. 0010.0286), take care that the side with the larger inner diameter (red) points against the chain.



*Figure 5 Plastic guide assembly*



Leave the Loctite to dry for at least 24 hours at room temperature.

---

### 7.5 Scope of delivery

Figure	Quantity	Item number	Item name
	1	10.028	Chain flail
	1	0010.028050G Pipe-ø 50 mm Pipe-ø 2 inch	Pin bolt chain
		0010.028075G Pipe-ø 75 mm Pipe-ø 3 inch	
		0010.028100G Pipe-ø 100 mm Pipe-ø 4 inch	
	1	0010.028050K Pipe-ø 50 mm Pipe-ø 2 inch	Set link chains
		0010.028075K Pipe-ø 75 mm Pipe-ø 3 inch	
		0010.028100K Pipe-ø 100 mm Pipe-ø 4 inch	
	1	0010.041G (0.5 Meter)	Pin bolt chain
	1	0010.028K (0.5 Meter)	Set link chains
	1	0010.0285M	Cover with cutter
	1	C127	Hex key 3 mm
	4	617.0612SPEZ	Threaded pin for chain
	1	0010.0286	Plastic guide
	1	09.001028	Tool case
	2	3.0406T	Cylinder screw with Tuflok

## 8 Index

### 8.1 Figure

<i>Figure 1 Blocked off &amp; signed work area</i> .....	14
<i>Figure 2 Oil Spray Bio, 500 ml</i> .....	20
<i>Figure 3 10.028</i> .....	21
<i>Figure 4 Converting to milling cutter</i> .....	25
<i>Figure 5 Plastic guide assembly</i> .....	25

### 8.2 Drawing

<i>Drawing 1 Chain length greater than pipe <math>\varnothing</math></i> .....	15
<i>Drawing 2 Maximum offset</i> .....	18
<i>Drawing 3 Explosion 10.028</i> .....	22
<i>Drawing 4 All chains for 10.028</i> .....	23

A large, high-quality photograph of water splashing, showing intricate details of bubbles and ripples, occupies the lower half of the page. The water is a clear, vibrant blue, and the background is a soft, light blue gradient.

enz® technik ag  
Schwerzbachstrasse 10  
CH-6074 Giswil / Switzerland  
Tel. +41 41 676 77 66  
info@enz.com  
www.enz.com