

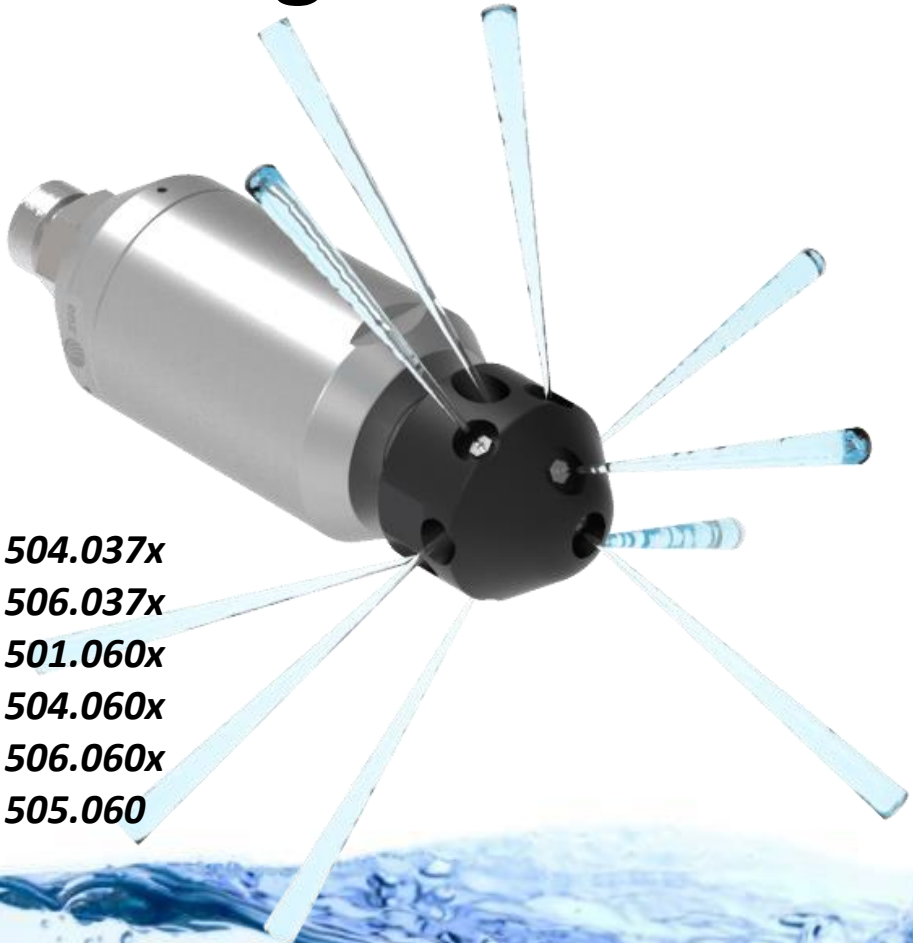

# Bulldog 1000



**504.037x**

**506.037x**

**501.060x**

**504.060x**

**506.060x**

**505.060**

**Operating manual**

**English**

**December 20 | Version 1.0**



# Table of Contents

<b>Table of Contents .....</b>	<b>2</b>
<b>Preface .....</b>	<b>4</b>
<b>Purpose of the document .....</b>	<b>4</b>
<b>1    ⚠ Safety .....</b>	<b>5</b>
1.1    ⚠ Consequences when disregarding the safety instructions .....	5
1.2    ⚠ Target group .....	5
1.3    ⚠ Requirements on the user .....	5
1.4    ⚠ Meaning of the general safety instructions .....	6
1.5    ⚠ Types of instructions in these operating instructions .....	6
1.6    ⚠ Intended use.....	7
1.7    ⚠ Safety instructions for modifications .....	7
1.8    ⚠ Personal protective equipment.....	8
1.9    ⚠ General safety instructions .....	10
1.10    Applied Standards and Directives.....	11
<b>2    Rights.....</b>	<b>12</b>
2.1    Copyright .....	12
2.2    Disclaimer .....	12
2.3    Guarantee conditions .....	12
<b>3    Environment .....</b>	<b>13</b>
3.1    Disposal .....	13
3.2    Environmental protection .....	13
<b>4    Technical data .....</b>	<b>14</b>
4.1    Introduction.....	14
4.2    Area of application .....	14
4.3    Designation of the parts .....	14
4.4    Legend for technical data .....	14
4.5    50x.037x Bulldog 1000 .....	15
4.6    50x.060x Bulldog 1000 .....	15
4.7    505.060 UB360 .....	15
<b>5    Installation.....</b>	<b>16</b>
5.1    Equipping.....	16
5.2    Assembly of the tools .....	16
5.3    Preparation work.....	16
5.4    Setting up the workplace.....	17
<b>6    Operation.....</b>	<b>18</b>
6.1    Operating principle.....	18
6.2    Operating the Bulldog 1000 .....	18
6.3    After use .....	20

**7 Maintenance.....21**

7.1 Changing the nozzle inserts.....21

7.2 Care .....23

7.3 Storage .....23

**8 Spare parts / Accessories .....24**

8.1 Nozzle inserts .....24

8.2 Accessories 50x.037x Bulldog 1000.....24

8.3 Accessories 50x.060x Bulldog 1000.....25

8.4 Accessories 505.060 UB360.....26

8.5 Maintenance accessories .....28

**9 Directory.....30**

9.1 Tables .....30

9.2 Figures .....30

**10 Notes .....31**

Version	Revision	Date	Signature
1.0	created	December 20	fkr

## Preface

### Dear customer

Thank you for the trust you have placed in us by the choice of our product. We would be more than pleased to receive any improvement suggestions and any constructive suggestions. We consider your cooperation as contribution to the optimum execution of our product and the corresponding documentation.

If you have any questions or suggestions, please contact our customer services directly:

**enz® technik ag**  
Schwerzbachstrasse 10  
CH-6074 Giswil / Switzerland

Tel. +41 41 676 77 66  
Fax. +41 41 676 77 67  
info@enz.com  
www.enz.com

Person responsible for the documentation:  
Fabian Krasniqi (Tech. Support / Head of QM)

Deviations resulting from product further developments as well as printing errors are reserved.

## Purpose of the document

These operating instructions serve to use our product in a comprehensive sense according to its intended use, correctly, effectively and safely. The users are informed about the risks and misuse.



### Important!

Before using the product for the first time, read these original operating instructions, handle accordingly and keep the document in a safe place for future reference.

---

Carefully read through the operating instructions before working with the cleaning tool. Make sure that it has been understood by all persons working with the product.

The operating instructions should be made available to the operating personnel at all times. If lost, a copy can be requested from your local dealer or direct from the manufacturer. The operating instructions can also be printed out online.

# 1 Safety

## 1.1 Consequences when disregarding the safety instructions

Disregarding the safety instructions may lead to accidents with serious personal injury, property or environmental damage.

The manufacturer is not liable for damage that results from disregarding the safety instructions.

## 1.2 Target group

These operating instructions are intended for all persons that are involved in assembly, commissioning or operation of the pipe cleaning tool.

## 1.3 Requirements on the user

All persons that are involved in the assembly, commissioning or operation of the tool must:

- be familiar with the cleaning work environment and have respective professional knowledge;
- be trained and instructed for the use of the product;
- have, read and understood the operating instructions, in particular the chapter « **Safety**».

Employees without the necessary knowledge must be trained. This can be carried out by the manufacturer of the pipe cleaning tool.

Only the maintenance and repair activities described in these operating instructions may be carried out. Other maintenance and repair work must be carried out by the manufacturer.



Observe the instructions in the chapter «**Maintenance**».

---

## 1.4 ⚠ Meaning of the general safety instructions

The general safety instructions inform you about potential residual risks which, despite correct use of the product.

To avoid personal injury, property or environmental damage, it is essential that all safety instructions are observed.

## 1.5 ⚠ Types of instructions in these operating instructions



### DANGER!

Designates dangers which, if disregarded, will result in **death** or serious injuries!



### WARNING!

Designates dangers which, if disregarded, may result in **death**, severe injuries or invalidity!



### CAUTION!













Designates dangers which, if disregarded, may result in injuries and significant property, financial or environmental damage!



Information for the correct and efficient use of the product.

## 1.6 Intended use

Due to the high pressures and temperatures, there is a risk of property damage as well as a risk of injury for the user and other persons. For the intended use of the product, the following points must be observed:

-  The product may be used exclusively in pipes or pipe-like channels. The profile to be cleaned must be closed at the top and surrounded all around by material.
-  The product is suitable for operation in steel pipes.
-  Consult the manufacturer for use in pipes made of other materials.
-  The product may only be operated with correct hose connections intact.
-  During operation, the cleaning area (shaft, feed, etc.) must be sufficiently secured.
-  During operation, **no** persons may remain in the pipes or at the ends of the pipes.
-  The max. pressure specified on the nozzle may **not** be exceeded.
-  The dirty water may **not** be directed into streams or rivers.
-  Before putting into operation each time, the correct state of the product must be checked.
-  Defects must be rectified before putting into operation.
-  Only flawless tools may be used. (For nuts, use only matching spanners)
-  Secure hose lines in such a way that they cannot be damaged during operation.
-  Only accessory parts provided and approved by **enz® technik ag** may be used.

## 1.7 Safety instructions for modifications

It is forbidden to carry out individual conversions or modifications to the pipe cleaning tool. Only parts authorised by the manufacturer may be used. The manufacturer is not liable for damage that results in conjunction with conversions on product made at your own authority.

## 1.8 ⚠ Personal protective equipment

Wearing personal protective equipment cannot eliminate dangers. PPE can however reduce or eliminate the impacts of dangers to persons. Accidents and occupational illness are avoided.



### Breathing protection

Isolation device (breathing apparatus) for remaining in dangerous atmospheres and for rescue operations. Isolation devices for self-rescue (self-contained open-circuit compressed air breathing apparatus and regenerative devices) for remaining in channels and for first supply of persons injured.



### Harness

Rescue harness or safety clothing with sewn-in neck eyelet. During the rescue operation, the rescue rope is attached to the neck eyelet. Lifting the injured person is carried out, e.g. By means of a rescue lifting device with automatic load backstop.



### Protective clothing

Closed work clothing that protects against water jets, contamination of skin and possible infections.



### Protective apron

At pressure ranges higher than 800 bar, an apron provides additional protection.



### Suitable shoes

The safety shoes should, in particular, offer good support, anti-slip and leak proof as well as protect against water jets. At pressure ranges higher than 800 bar, gaiters provide additional protection.



### Hand protection

Suitable gloves protect against hand injuries and contact against substances hazardous to health and contaminated water.



### Hard hat

The hat protects the persons head against falling objects as well as against knocking against fixed objects.



### Face protection

A suitable face protection protects against water jets and contamination.

**Ear protection**

For noise, e.g. ear protector capsules with integrated headset can be worn.

**Eye protection**

If there is a danger by splitters, splashing of hazardous substances, etc. eyes must be protected.

**Gas detector**

In event of poisonous vapours in work areas, a suitable gas detector may be useful.

**Network-independent lighting**

A splash-proof torch or a lamp fixed to a hard hat must be carried.

**Hose guard**

With pressure ranges higher than 800 bar, a suitable hose guard (e.g. Made of Kevlar) provides additional protection against water jets.

## 1.9 ⚠️ General safety instructions

### Danger! | High-pressure water jets



Defective products or incorrect operation of the product increases the dangers from splash water under pressure. Before operation, ensure the trouble-free state of the product. Powerful water jets may cause heavy injuries or even sever limbs. Non-observance of the safety instructions may result in **death** or very serious injuries!

### Danger! | Poisonous substances



Channels, pipes and tanks may contain poisonous vapours. Wear the prescribed protective equipment such as gas masks, gas alarms and rescue harnesses. Inhaling poisonous vapours or air contaminated with particles may result in **death** or very serious injuries!

### Danger! | Suspended load



In the working environment, there is a danger by suspended loads such as tools or objects to be cleaned. Never stand under suspended loads. **Death** or very serious injuries may result from objects falling down!

### Danger! | Falling objects



In the area of open shafts, objects may fall in. When inserting the product, never remain directly under the shaft opening. Secure the shaft access against parts that fall down. Do not throw any tools or objects into the shaft. Never access shafts that are in danger of collapsing. Persons could be buried. Non-observance of safety instructions may result in **death** or serious injuries!

### Warning! | Corrosive substances



Channels, pipes and tanks may contain corrosive or other harmful substances. Wear the respective protective clothing. Use the prescribed protective equipment. Chemical burns to skin and eyes or infections may be the consequence!

**Warning! | Risk of falling**

In the area where work is carried out using the product, open shafts are to be expected. Open shafts must be indicated. Take care where you step. Falling may result in **death** or very serious injuries!

**Warning! | Hand injuries**

With a modification of the product, there is a risk of hand injuries. Wear gloves when working. Observe where you hold the product. Carry heavy devices with the assistance of a second person. If disregarded, this may result in crushing, abrasion up to the severing of limbs.

**Caution! | Tipped objects**

With a modification of the product, there is a risk of hand injuries from sharp edges. Wear gloves when working. Observe where you hold the product. If disregarded, this result in cut injuries!

**Caution! | Risk of falling**

In the area where work is carried out with the product, lines and objects are to be expected on the ground. Take care where you step. Keep the operating area clean and tidy. Falling caused by tripping may result in injury!

**Caution! | Hot surfaces**

The product may heat strongly during operation. This can result in burns!

## 1.10 Applied Standards and Directives

- Machinery Directive: 2006/42/EC
- EN1829-1:2018 High-pressure water jet machines - Safety requirements - Part 1: Machines
- EN1829-2:2008 High-pressure water jet machines - Safety requirements - Part 2: Hoses, hose lines and connectors
- EN ISO 4413:2010 Hydraulic fluid power - General rules and safety requirements for systems and their components
- Recommended procedure for the use of high-pressure water jet devices (WJTA-IMAC)
- Recommended procedure for high-pressure water jets (WJA)
- Industrial Cleaning Foundation (Stiftung Industrielle Reinigung) (The Netherlands) – SIR

## 2 Rights

### 2.1 Copyright

This manual may not be partially or completely copied, photocopied, reproduced, translated or converted in an electronically of machine-readable form without the prior written consent of **enz® technik ag**.

©2020 enz® technik ag, CH-6074 Giswil.  
All rights reserved.

### 2.2 Disclaimer

The manufacturer is not liable for damage that:

- has resulted in conjunction with modifications to the product carried out at your own authority.
- have resulted from disregarding the safety instructions.

### 2.3 Guarantee conditions

In line with our terms of sales and delivery, we issue a guarantee. However, the guarantee is omitted:

- When used under conditions stipulated otherwise by us.
- When using replacement or accessory parts that are not original from **enz® technik ag**.
- In event of damage caused by:
  - Incorrect use
  - Non-observance of the operating instructions
  - Unsuitable operating material
  - Routing of the hose or pipelines incorrectly or inappropriately
  - modifications or conversions to the product at your own authority.

## 3 Environment

### 3.1 Disposal

Old devices have valuable recyclable materials that should be recycled. Therefore, please dispose of old devices via enz® technik ag or suitable collecting points.

### 3.2 Environmental protection

Please observe that surfaces can only be cleaned where the composition of the contamination known. Chemicals or other poisonous substances must never be released to the environment. Take care to avoid excessive use of water. In this way, you help to protect natural resources.

## 4 Technical data

### 4.1 Introduction

The Bulldog 1000 rotating nozzles have been especially designed for inner pipe cleaning with pressures up to 1,000 bar (14,500 psi). They are suitable for the removal of the hardest deposits on the pipe walls. Moreover, the front jets directed to the front loosen deposits where there are total blockages. Thanks to its sealing system, the Bulldog 1000 rotating nozzles are leak-free and thus more efficient. With sufficient performance, a thrust piece can be inserted in-between the nozzle and hose.

### 4.2 Area of application

- Opening and polishing of pipes (inner pipe cleaning)
- Cleaning of heat exchangers
- General industrial cleaning

### 4.3 Designation of the parts

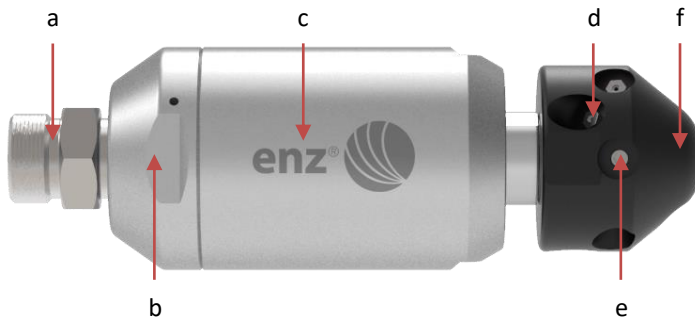

Figure 1: Designation of the parts

#### 4.3.1 Legend

- |   |                      |   |               |   |              |
|---|----------------------|---|---------------|---|--------------|
| a | High-pressure nipple | c | Housing       | e | Threaded pin |
| b | Rotor rear part      | d | Nozzle insert | f | Head         |

### 4.4 Legend for technical data

	Connecting thread [“]		Rotating nozzles / bore
$\varnothing \times L$	Mass		Area of application
	Maximum operating pressure		min. flow rate at 1,000 bar
	Front jet		

Table 1: Legend for technical data

### 4.5 50x.037x Bulldog 1000





Order no.				Q		ØxL					
				mm	inch	mm	inch	l/min	US gpm	bar	psi
504.037	M24x1.5	6xM6	-	40-100	1.6-3.9	38x142	1.5x5.6	23	6.1	1,000	14,500
504.037N	1/2" NPT	6xM6	-	40-100	1.6-3.9	38x142	1.5x5.6	23	6.1	1,000	14,500
506.037	M24x1.5	6xM6	2xM4	40-100	1.6-3.9	38x142	1.5x5.6	27	7.1	1,000	14,500
506.037N	1/2" NPT	6xM6	2xM4	40-100	1.6-3.9	38x142	1.5x5.6	27	7.1	1,000	14,500

Table 2: Technical Data 50x.037x

### 4.6 50x.060x Bulldog 1000





Order no.				Q		ØxL					
				mm	inch	mm	inch	l/min	US gpm	bar	psi
501.060	M24x1.5	6xM6	-	65-150	2.6-5.9	60x186	2.4x7.3	40	10.6	1,000	14,500
501.060N	1/2" NPT	6xM6	-	65-150	2.6-5.9	60x186	2.4x7.3	40	10.6	1,000	14,500
504.060	M24x1.5	6xM6	-	65-150	2.6-5.9	60x186	2.4x7.3	46	12.2	1,000	14,500
504.060N	1/2" NPT	6xM6	-	65-150	2.6-5.9	60x186	2.4x7.3	46	12.2	1,000	14,500
506.060	M24x1.5	6xM6	2xM6	65-150	2.6-5.9	60x186	2.4x7.3	50	13.2	1,000	14,500
506.060N	1/2" NPT	6xM6	2xM6	65-150	2.6-5.9	60x186	2.4x7.3	50	13.2	1,000	14,500

Table 3: technical data 50x.060x

### 4.7 505.060 UB360





Order no.				Q		ØxL					
				mm	inch	mm	inch	l/min	US gpm	bar	psi
505.060	M24x1.5	6xM8	-	300-1100	11.8-43.3	300x1003	11.8x39.5	40	10.6	1,000	14,500

Table 4: Technical data 505.060

## 5 Installation

### 5.1 Equipping

To match Bulldog 1000 optimally to the pump, enz<sup>®</sup> technik ag needs the following parameters for each order:

- |                     |         |        |
|---------------------|---------|--------|
| • Pumping capacity: | l/min   | US gpm |
| • Pump pressure:    | bar     | psi    |
| • Hose diameter:    | mm      | inch   |
| • Hose length:      | m       | feet   |
| • Hose material:    | Plastic | Rubber |



If changes are made to the parameter, the tool must be re-calibrated

### 5.2 Assembly of the tools

The Bulldog 1000 is supplied ready for use. After unpacking, check, that the delivery is complete. Then the Bulldog 1000 is screwed onto the high-pressure hose. The Bulldog 1000 nozzles are available in different thread dimensions which are apparent in chapter «Technical data» from page [14](#).

As standard, the tool rotates counter-clockwise. This means that it cannot be disconnected from the hose during operation.



When screwing on the pressure hose, make sure that no contamination can enter in the tool. Particles may clog the inserts.

### 5.3 Preparation work

Knowledge of the following points are useful for the preparation and setting of the tool:

- Pipe run
- Internal diameter of the pipe to be processed
- Material quality of the pipe to be processed
- Type of contamination in the pipe
- Access possibilities to the pipe

## 5.4 Setting up the workplace

Before starting work, the following measures must be taken:

- ⚠ Install any barriers and protective equipment (Triopan warning sign, fencing ropes, etc.).
- ⚠ Obtain the necessary information about the waste water introduced to the pipe (chemical substances, gases, vapours, etc.).
- ⚠ The necessary measuring devices such as explosimeter, oxygen meter, gas alarm, etc. must be ready for use.
- ⚠ The working area must be cordoned off such that there is no danger for other persons.
- ⚠ Make sure that the suitable nozzles are present for the pipe cleaning. The area of application of each nozzle is apparent in chapter «Technical data», from page **14**.
- ⚠ The pipe run (plans) must be known before starting work in order to prevent the nozzle from exiting at the end of the line. Possible exit location must be monitored by support staff.
- ⚠ The surface of the workplace must be clean and have sufficient grip, loose obstructions at the workplace must be removed.
- ⚠ Ensure that on workplace is sufficiently illuminated.
- ⚠ The workplace must be dimensioned such that the high-pressure blaster has sufficient freedom of movement and can assume a safe working posture.
- ⚠ The workplace must ensure that water can drain or run away.
- ⚠ Scaffolding must be setup in a stable manner and secured against tipping, moving and falling over.
- ⚠ Work platforms must be setup in a stable manner. They must not move when carrying out cleaning work.
- ⚠ Scaffolding and work platforms must comply with regards to the standards on occupational protection and may only be installed by trained specialist personnel.
- ⚠ Before starting work, the high-pressure machine operator and high-pressure blaster must agree clearly defined hand signals for switching the high-pressure system on and off as under certain circumstances, acoustic communication may not be possible due to the noise level.
- ⚠ Loose parts to be cleaned must be secured before commencing work.

## 6 Operation

### 6.1 Operating principle

The high-pressure hose is screwed onto the connecting thread (1). From there, the water enters the head (3) directly and leak-free through the rotor in the housing (2). The semi-radial jets to the rear (4) ensure for sufficient pulling force and rinse the loosened deposits away to the rear. The radial jets (5) loosen the deposits and polish the pipe at the same time. The two front jets (6) open the pipe where there are total blockages.

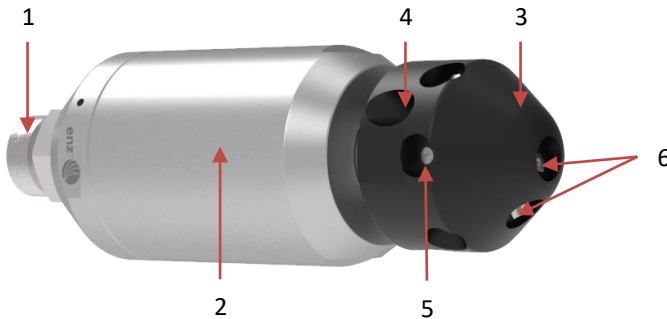

Figure 2: Operating principle Bulldog 1000

### 6.2 Operating the Bulldog 1000

1. Flush the entire system.
2. Measure the length of the pipe to be cleaned (marking on the shaft). Check the marking during cleaning.
3. Screw the Bulldog 1000 onto the high-pressure hose.
4. Push the Bulldog 1000 completely into the pipe to be cleaned.
5. Increase the pressure to the work pressure.
6. Start cleaning the pipe.
7. When pulling Bulldog 1000 back, keep the water running. This prevents dirty water running into the inside of the Bulldog 1000 through the openings.



#### DANGER!

Never operate the tool outside of pipes. This may result in **death** or severe injuries.

**DANGER!**



The maximum work pressure must never be exceeded; there is **potential mortal danger** (see “Technical data” from page **14**).  
If the nozzle ruptures, walls of the pipe may be pierced through and parts thrown away at high speed.

**DANGER!**



Operation of high-pressure water jet systems directly under or in the vicinity of high-voltage plants is forbidden. This may result in **death** or severe injuries.

**DANGER!**



When working in closed rooms, poisonous vapours may accumulate. Wear the prescribed protective equipment such as gas masks, gas alarms. Inhaling poisonous vapours or air contaminated with particles may result in **death** or severe injuries!

**WARNING!**



When working with high-pressure water jets, an emergency escape person who maintains permanent visual contact with the high-pressure cleaner during the cleaning is absolutely essential.

**CAUTION!**



Work only with filtered water (filter size 0.005 mm or 0.001 mm (1 µm) and smaller). Otherwise there is a risk of over pressure from clogging.



To increase safety during work, we recommend using a hose break-age protection.



With strongly contaminated pipes, we recommend that the tool is pulled back at regular distances. This prevents clogging from frag-ments and detached material.



When cleaning with hot water (max. 100°C) or with additives, it must be observed that the entire system must be suitable for this.



After use, blast through the tools with compressed air and dry them up. Preserve the tool with Motorex Oil Spray Bio (C191).

### 6.3 After use

After finishing the cleaning work, the following points must be observed:

1. Check the nozzle inserts for blockage. The best way to do this is when you still have the tool on the hose, and check if water runs out on each nozzle insert.
2. Disassemble the tool from the hose.
3. Rinse the tool with fresh water.
4. Dry the tool and preserve it with Oil Spray Bio (Art. no. C191).

## 7 Maintenance

The maintenance and repair activities described in these operating instructions may only be carried out by users who have the necessary knowledge.

### 7.1 Changing the nozzle inserts

After being used each time, the nozzle inserts must be checked visually for damage in order to guarantee an optimum cleaning performance. The wear depends on the degree of contamination of the water used.



#### CAUTION!

Worn nozzle inserts impair the cleaning performance and there is an increased risk when working with higher pressures. This can result in damage to the tool.

Another reason to change nozzle inserts is a repositioning. In this case, the JetCalc must be used for determination of the nozzle inserts.

Follow the next steps in order to replace the nozzle inserts:

1. Clean the nozzle insert. During the approx. 10 seconds, heat it with the gas torch (C158).
2. Disassemble the nozzle insert using the socket spanner WAF5 (C104 or C261).
3. Clean the threaded hole and the new nozzle insert, e.g. with acetone.



4. Coat the thread of the nozzle insert with Loctite 638 (C109).
5. Mount the nozzle insert using the socket spanner WAF5 (C104 or C261).
6. Leave the adhesive to harden for at least 48 hours at room temperature (approx. 22°C).



*Table 5: Changing the nozzle inserts*



**CAUTION!**

The nozzle inserts must be replaced by identical nozzle inserts. This can result in the speed and kick-back force changing.



**CAUTION!**

Never use a pliers with teeth. These may damage the tool or the hose. This may lead to the tool bursting during operation.



The nozzle inserts and the female thread on the tool must be clean, dry and free from oil and grease.

---

## 7.2 Care

The Bulldog 1000 rotting nozzles must be thoroughly cleaned after being used each time. After cleaning, the Bulldog 1000 rotating nozzles must be preserved with Motorex Oil Spray Bio (C191).

## 7.3 Storage

The Bulldog 1000 rotting nozzles must be stored in a dry location protected from dust. We recommend using a plastic container with lid.

## 8 Spare parts / Accessories

### 8.1 Nozzle inserts

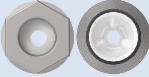



Figure	Designation	Article number
	Nozzle insert M4	22.04
	Nozzle insert M6	22.06
	Threaded pin M4	22.04B
	Threaded pin M6	22.06B

Table 6: Nozzle inserts

### 8.2 Accessories 50x.037x Bulldog 1000

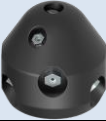

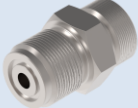

Figure	Designation	Article number
	Head for Bulldog 50x.037x	00500.0375
	Centralizer for Bulldog 50x.037x	500.037100
	High-pressure nipple M24x1.5	00500.06024
	High-pressure nipple 1/2" NPT	00500.06050









Table 7: Accessories Bulldog 50x.037x

### 8.3 Accessories 50x.060x Bulldog 1000

Figure	Designation	Article number
	Head for Bulldog 50x.060x	00500.06051
	Centralizer for Bulldog 50x.060x	500.060100
	High-pressure nipple M24x1.5	00500.06024
	High-pressure nipple 1/2" NPT	00500.06050
	Thrust piece M24x1.5	00500.0608
	Thrust piece 1/2" NPT	00500.0608N

Table 8: Accessories Bulldog 50x.060x

**8.4 Accessories 505.060 UB360**

Figure	Designation	Article number
	Scissor skid 1000	500.060300
	Scissor skid 1000 with hand lever	500.060300J
	Scissor skid 1000 with polyurethane wheels	500.060300P
	Scissor skid 1000 with steel wheels	500.060300S
	Scissor skid 1000 with polyurethane wheels and hand lever	500.060300JP
	Scissor skid 1000 with steel wheels and hand lever	500.060300JS
	Propeller head RGS 3 mm	00500.0605003
	Propeller head RGS 7 mm	00500.0605007
	Propeller head RGS 11.5 mm	00500.0605012

*Table 9: Accessories UB360*



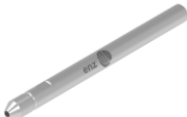
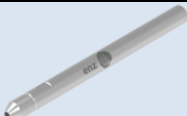

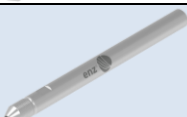



Figure	Designation	Article number
	Rotary union 50x.060x	00500.060
	Pulling eye M10	C360
	Triangle strut 1000	00500.0609
	Set propeller tube 1000 50 mm	500.06009050
	Set propeller tube 1000 120 mm	500.06009120
	Set propeller tube 1000 200 mm	500.06009200
	Set propeller tube 1000 300 mm	500.06009300
	Set propeller tube 1000 400 mm	500.06009400
	Polyurethane wheel	00100.0603002
	Steel wheel	00100.0603003

Table 10: Accessories UB360

Figure	Designation	Article number
	Star handle screw	00100.0603004
	Hand lever Jaccard handle	00100.0603005

Table 11: Accessories UB360

## 8.5 Maintenance accessories







Figure	Designation	Article number
	Wiha socket wrench 3.5 mm for M4	C104
	Wiha socket wrench 5 mm for M4	C101
	Futuro socket wrench 3.5 mm for M4	C261
	Futuro socket wrench 5 mm for M4	C149
	Gas torch	C158
	Oil Spray Bio	C191
	Loctite 243 50 ml	C192

Table 12: Maintenance accessories



Figure	Designation	Article number
	Loctite 638 50 ml	C109
	Nozzle gauge with 20 pins 0.45-1.50 mm	C200
	Nozzle gauge with 16 pins 1.50-3.00 mm	C201
	Nozzle cleaning set	C202

Table 13: Maintenance accessories

## 9 Directory

### 9.1 Tables

<i>Table 1: Legend for technical data</i> .....	14
<i>Table 2: Technical Data 50x.037x</i> .....	15
<i>Table 3: technical data 50x.060x</i> .....	15
<i>Table 4: Technical data 505.060</i> .....	15
<i>Table 5: Changing the nozzle inserts</i> .....	22
<i>Table 6: Nozzle inserts</i> .....	24
<i>Table 7: Accessories Bulldog 50x.037x</i> .....	24
<i>Table 8: Accessories Bulldog 50x.060x</i> .....	25
<i>Table 9: Accessories UB360</i> .....	26
<i>Table 10: Accessories UB360</i> .....	27
<i>Table 11: Accessories UB360</i> .....	28
<i>Table 12: Maintenance accessories</i> .....	28
<i>Table 13: Maintenance accessories</i> .....	29

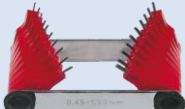
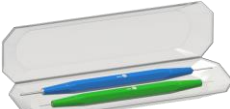
### 9.2 Figures

<i>Figure 1: Designation of the parts</i> .....	14
<i>Figure 2: Operating principle Bulldog 1000</i> .....	18

## 10 Notes

A large, dynamic splash of clear blue water occupies the lower half of the page. The water is captured in mid-air, with numerous bubbles and droplets visible, creating a sense of freshness and movement. The background is a light, clean white, which makes the blue water stand out prominently.

enz® technik ag  
Schwerzbachstrasse 10  
CH-6074 Giswil / Switzerland  
Tel. +41 41 676 77 66  
Fax +41 41 676 77 67  
info@enz.com  
www.enz.com